

# PARTS CATALOGUE

## CHALLENGER 150 CXL-150

---



# CONTENTS

## PARTS ITEM:

- 01 CRANK CASE, L COVER, SPINDLE ASSY.
- 02 CRANK SHAFT, PISTON, CYLINDER, TENSIONER
- 03 OIL PUMP, STARTING MOTOR
- 04 RIGHT CRANK CASE COVER, GENERATOR
- 05 COVER HEAD, HEAD, CAM SHAFT, VALVE
- 06 FAN COVER, SHROUD
- 07 DRIVEN RULLEY (CVT)
- 08 TRANSMISSION
- 09 GEAR SHAFT LEVER, SAFETY SWITCH
- 10 AIR CLEANER
- 11 CARBURETOR (MANUAL CHOKE WITH THREE THR
- 11 CARBURETOR (MANUAL CHOKE WITHOUT THREE
- 11 CARBURETOR (AUTO-BY/STARTER)
- 12 OIL COOLER
- 13 ENGINE
- 14 MUFFLER
- 14 MUFFLER(U.S)
- 15 FRAME
- 16 FENDER
- 17 SWING ARM
- 18 SEAT
- 19 FUEL TANK
- 19 FUEL TANK
- 20 SUSPENSION
- 21 FRONT WHEEL
- 22 REAR WHEEL
- 23 FRONT BRAKE SYSTEM

- 24 REAR BRAKE (HYDRAULIC DISC BRAKE)
- 24 REAR BRAKE (DRUM BRAKE)
- 25 HANDLE BAR (HYDRAULIC DISC BRAKE)
- 25 HANDLE BAR (DRUM BRAKE)
- 26 BUMPER, FOOTREST
- 27 REAR WHEEL AXLE
- 28 STEERING
- 29 ELECTRICAL EQUIPMENT
- 30 PACKING CASE,EXTERNAL(DRUM BRAKE)
- 31 ACCESSORIES
- 32 KIT DESCRIPTION
- 33 BUMPER ASSY
- 34 TOOL
- 35 SERVICE KITS, BRAKE CALLIPER

**N & sign meaning: not available to sale**

# 1. CRANK CASE · L COVER · SPINDLE ASSY

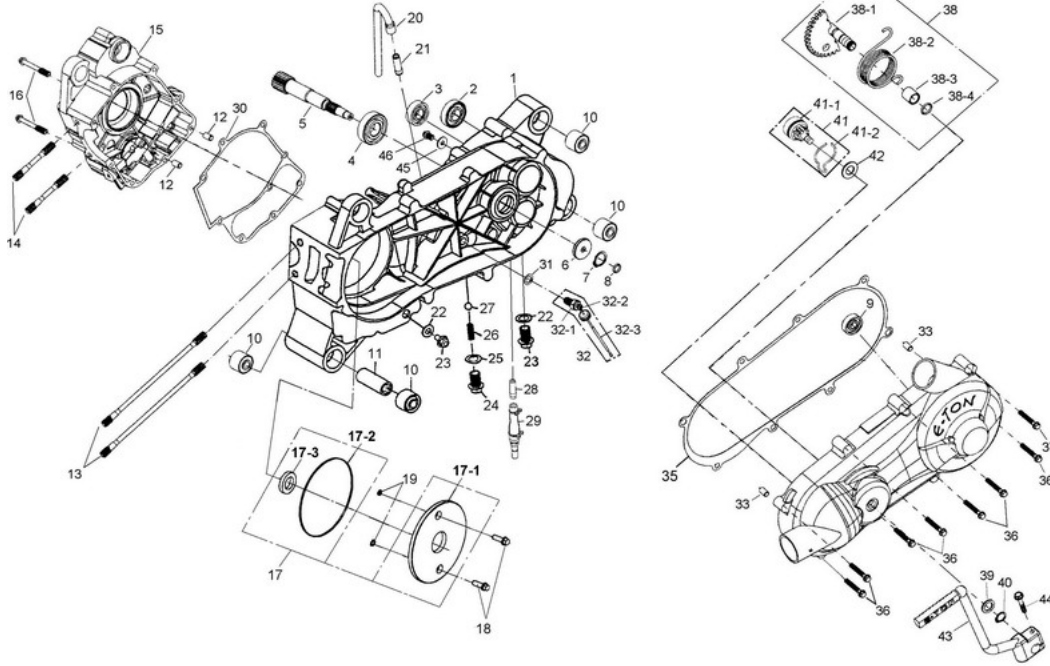

ITEM	AVAIL	PART NO.	NAME	QTY
01			CRANK CASE, L COVER, SPINDLE ASSY.	
01-1		A1200-V30-0900	CRANK CASE ASSY LEFT	1
01-2		I6100-62030	BEARING, BALL RADIAL	1
01-3		I6100-62020	BEARING, BALL, RADIAL	1
01-4		I6100-62043	BEARING, BALL, RADIAL	1
01-5		B3411-V30-9000	SHAFT DRIVE (13T)	1
01-6		I1202-A04-0000	OIL SEAL (20x32x6)	1
01-7		I4510-20000	CIRCLIP EX	1
01-8		I4608-09424	O-RING	1
01-9		I6150-62000-10	BEARING, BALL, RADIAL	1
01-10		A1103-V30-0000	RUBBER BUSH ENGINE HANGER	4
01-11		A8255-V30-0000	BOSS (A)	1
01-12		I4301-08140	KNOCK PIN	2
01-13		I0032-08208-0H	STUD BOLT (B)	2
01-14		I0031-08200-0H	STUD BOLT (A)	2
01-15		A1100-V30-0900	CRANK CASE COMP R (OIL COOLER)	1
01-16		I6001-06050-0H	BOLT FLANGE	2
01-17		A1250-A14-0000	PLATE COMP, L CRANK CASE	1
01-17-1		A1207-A14-0001	PLATE CRANK CASE L	1
01-17-2		I4608-10720	O-RING	1
01-17-3		I1202-A26-9000	OIL SEAL (L)	1
01-18		I6001-06020-0H	FLANGE BOLT, HEX.	2
01-19		I4608-06017	O-RING	2
01-20		A1221-V30-0000	HOSE BREATHER	1
01-21		A1106-A00-0000	CONNECTER TUBE BREATHER	1
01-22		I4104-12120	WASHER	2
01-23		I2800-12015-0C	BOLT, HEX.	2
01-24		B4305-V30-0000	SCREW FIXING	1
01-25		I4104-14210	WASHER	1
01-26		B4306-V30-0000	SPRING FIXING	1
01-27		B4307-V30-0000	BALL BEARING	1
01-28		A1206-V30-0000	CONNECTER TUBE BREATHER	1
01-29		A7232-V30-0000	DRAIN TUBE	1
01-30		A1192-A08-0000	GASKET CRANK CASE	1
01-31		I4104-10010	WASHER	1
01-32		C5750-V30-0000	NEUTROL SWITCH COMP	1
01-32-1	N	C5752-V30-0000	NEUTRAL SWITCH CONNECTER	1
01-32-2	N	I3500-04006	SCREW, CROSS RECESS HEAD	1

01-32-3	N	C5751-V30-0000	WIRING COMP	1
01-33		I4301-10140	KNOCK PIN	2
01-34		A1341-V30-0300	COVER L SIDE	1
01-35		A1395-V30-0000	GASKET L COVER	1
01-36		I6001-06040-0C	BOLT, HEXAGON HEAD	7
01-37		I6001-06040-0H	FLANGE BOLT, HEX.	1
01-38		B825A-V30-0000	SPINDLE ASSY. KICK STARTER	1
01-38-1	N	B8250-A14-0001	SPINDLE COMP KICK START	1
01-38-2		B8281-A14-0000	SPG KICK STARTER	1
01-38-3		B8253-V30-0000	BOSS KICK SPINDLE (B)	1
01-38-4		I4608-13824A	O-RING	1
01-39		I4104-14520A	WASHER	1
01-40		I4510-14000	CIRCLIP EX	1
01-41		B823A-A14-0001	GEAR ASSY STARTER IDLE	1
01-41-1		B8230-A14-0001	GEAR COMP STARTER IDLE	1
01-41-1	N	B8230-A14-0001	GEAR COMP STARTER IDLE	1
01-41-2		B8223-A14-0000	SPG. FRICTION START GEAR	1
01-41-2	N	B8223-A14-0000	SPG. FRICTION START GEAR	1
01-42		I4102-10505	WASHER	1
01-43		B8300-V30-9000	ARM COMP KICK STARTER	1
01-44		I5701-06035-0C	BOLT , HEXAGON HEAD	1
01-45		I4104-06515A	WASHER	1
01-46		I6001-06012-0H	FLANGE BOLT, HEX.	1

## 2. CRANK SHAFT · PISTON · CYLINDER · TENSIONER

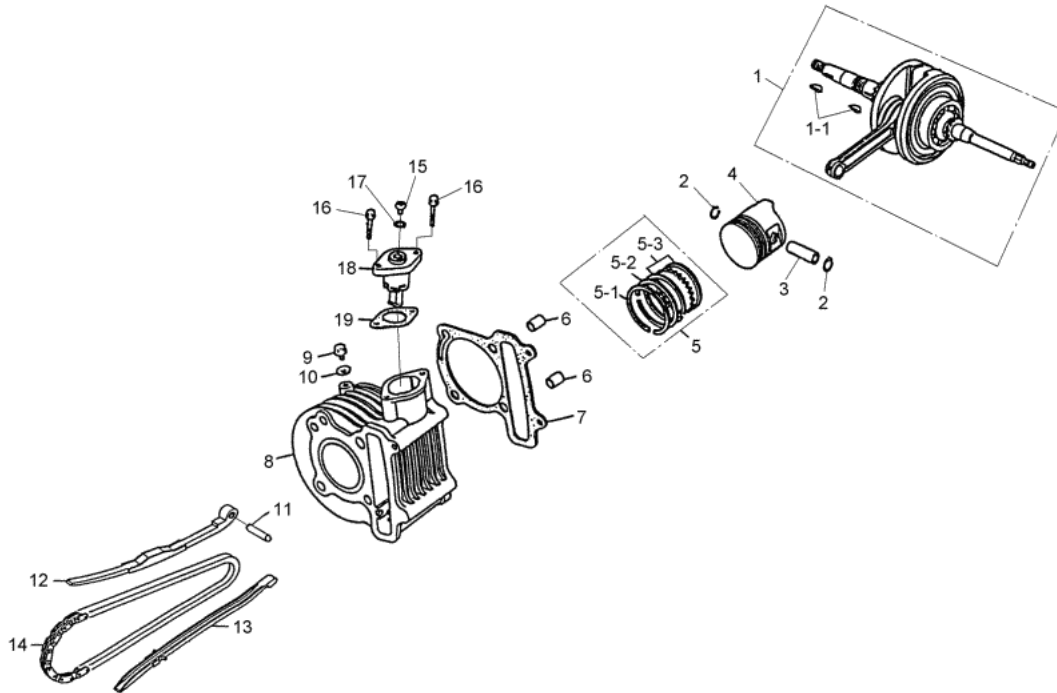

ITEM	AVAIL	PART NO.	NAME	QTY
02			CRANK SHAFT, PISTON, CYLINDER, TENSIONER	
02-1		A3000-V30-0001	CRANK SHAFT COMP	1
02-1-1		I4401-25046	WOODRUFF KEY	2
02-2		I4601-15000	CLIP, PISTON PIN 15mm	2
02-3		A3111-A08-0000	PIN, PISTON	1
02-4		A3101-A08-0000	PISTON	1
02-5		A3011-A08-0000	RING SET, PISTON	1
02-5-1	N	A3121-A08-0000	RING PISTON TOP	1
02-5-2	N	A3131-A08-0000	RING PISTON 2ND	1
02-5-3	N	A3141-A08-0000	RING PISTON OIL	1
02-6		I4301-10140	KNOCK PIN	2
02-7		A2191-A08-0000	GASKET CYLINDER	1
02-8		A2100-A08-0000	CYLINDER COMP	1
02-9		I5801-06012-0C	FLANGE BOLT, HEX.	1
02-10		I4104-06512	WASHER	1
02-11		I4301-06240	KNOCK PIN	1
02-12		A4510-A04-0000	TENSIONER CAM CHAIN	1
02-13		A4610-A04-0000	GUIDE COMP CAM CHAIN	1
02-14		A4401-A07-0000	CHAIN CAM	1
02-15		I3700-06005	SCREW, OVAL TAP	1
02-16		I6001-06020-0H	FLANGE BOLT, HEX.	2
02-17		I4608-09515	O-RING	1
02-18		A4520-A04-0000	LIFTER ASSY .TENSIONER	1
02-19		A4523-A04-0000	GASKET TENSIONER LIFTER	1

### 3.OIL PUMP · STARTONG MOTOR

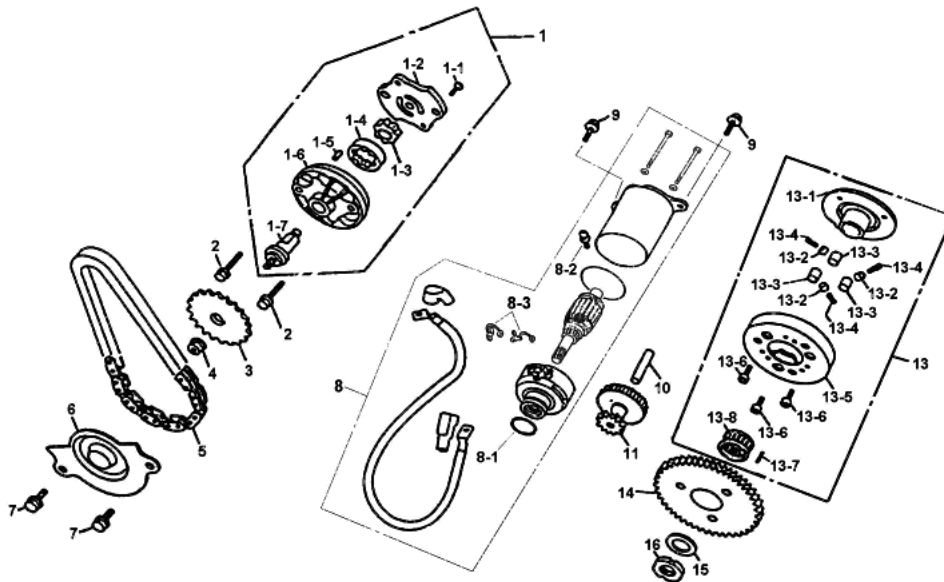

ITEM	AVAIL	PART NO.	NAME	QTY
03			OIL PUMP, STARTING MOTOR	
03-1		A5100-A07-0000	PUMP ASSY. OIL	1
03-1-1		I3500-03010-0G	SCREW,CROSS RECESS HEAD	1
03-1-2		A5116-A04-0000	PLATE OIL PUMP	1
03-1-3		A5331-A07-0000	ROTOR OIL PUMP INNER	1
03-1-4		A5332-A07-0000	ROTOR OIL PUMP OUTER	1
03-1-5		I4303-04065	KNOCK PIN	1
03-1-6		A5101-A07-0000	BODY OIL PUMP	1
03-1-7		A5132-A04-0000	SHAFT OIL PUMP	1
03-2		I3600-06030-0H	SCREW ,CROSS RECESS HEAD	2
03-3		A5133-A04-0000	SPROCKET OIL PUMP DRIVEN	1
03-4		I4050-0600G	NUT	1
03-5		A5141-A04-0000	CHAIN OIL PUMP	1
03-6		A5711-A04-0000	SEPARATOR OIL	1
03-7		I6001-06012-0H	FLANGE BOLT, HEX.	2
03-8		C1200-V30-0000	MOTOR START COMP	1
03-8-1		I1309-24031	O-RING	1
03-8-2		I3892-04006-08	SCREW WASH	2
03-8-3		C1221-A04-0000	CARBON BRUSH	2
03-9		I6001-06016-0C	BOLT , HEXAGON HEAD	2
03-10		B8102-A04-0000	SHAFT STARTER REDUCTION GEAR	1
03-11		B8101-A04-0000	GEAR STARTER REDUCTION	1
03-13		B812A-A04-0000	OUTER ASSY .STARTING CLUTCH	1
03-13-1		B8125-A04-0000	FLANGE STARTING CLUTCH	1
03-13-2		B8126-A04-0000	CAP SPRING ROLLER SP	3
03-13-3		I6220-A0100	ROLLER	3
03-13-4		B8127-A04-0000	SPRING STARTING CLUTCH ROLLER	3
03-13-5		B8120-A04-0000	OUTER COMP STARTING CLUTCH	1
03-13-6		I6600-06010-0A	SOCKET BOLT	3
03-13-7		I4303-05060	KNOCK PIN	1
03-13-8		I1110-2832168	BEARING, NEEDLE	1
03-14		B8110-A04-0000	GEAR COMP STARTING CLUTCH	1
03-15		I4104-22225	WASHER	1
03-16		I0231-A04-0000	NUT LOCK	1

#### 4. RIGHT CRAANK CASE COVER, GENERATOR

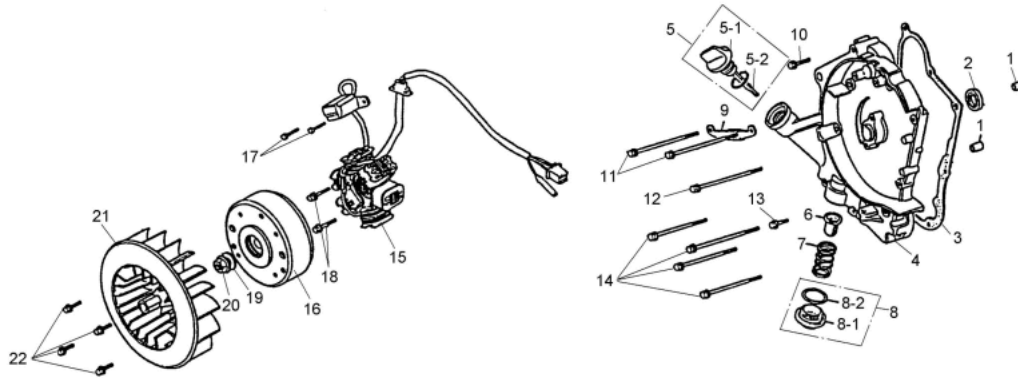

ITEM	AVAIL	PART NO.	NAME	QTY
04			RIGHT CRAANK CASE COVER, GENERATOR	
04-1		I4301-08140	KNOCK PIN	2
04-2		I1201-A26-9000	OIL SEAL (R)	1
04-3		A1394-A04-0000	GASKET R CRANK CASE COVER	1
04-4		A1331-V30-0900	COVER R CRANK CASE	1
04-5		A5650-A04-0000	GAUGE COMP OIL LEVEL	1
04-5-1		A5651-A04-0000	GAUGE OIL LEVEL	1
04-5-1	N	A5651-A04-0000	GAUGE OIL LEVEL	1
04-5-2		I4608-18030	O-RING	1
04-5-2		I4608-12625	O-RING	1
04-6		A5421-A00-0000	SCREEN, OIL FILTER	1
04-7		A5426-A04-0000	SPG OIL FILTER SCREEN	1
04-8		A2360-A04-0001	HOLE CAP TAPPET COMP	1
04-8-1		I4608-30832	O-RING	1
04-8-1		A2361-A04-0000	HOLE CAP TAP ADJUSTING	1
04-8-2		A2361-A04-0000	HOLE CAP TAP ADJUSTING	1
04-8-2		I4608-30832	O-RING	1
04-9		C2961-A04-0000	CLAMPER A.C.G GENERATOR	1
04-10		I6001-06040-0C	BOLT, HEXAGON HEAD	1
04-11		I6001-06110-0C	BOLT , HEXAGON HEAD	2
04-12		I6001-06100-0H	FLANGE BOLT, HEX.	1
04-13		I6001-06032-0H	BOLT , HEXAGON HEAD	1
04-14		I6001-06095-0C	BOLT , HEXAGON HEAD	4
04-15		C1120-V30-9000	STARTOR COMP(CDI)	1
04-16		C1110-V30-0000	FLYWHEEL COMP	1
04-17		I3412-05014-0H	BOLT, HEX.	2
04-18		I6001-06020-0H	FLANGE BOLT, HEX.	2
04-19		I4104-12522	WASHER	1
04-20		I4050-12110-0H	FLANGE NUT, HEX.	1
04-21		A9510-A04-0000	FAN COMP COOLING	1
04-22		I6001-06018-0H	BOLT , HEXAGON HEAD	4

## 5. HEAD COVER 、 HEAD 、 CAM SHAFT 、 VALVE

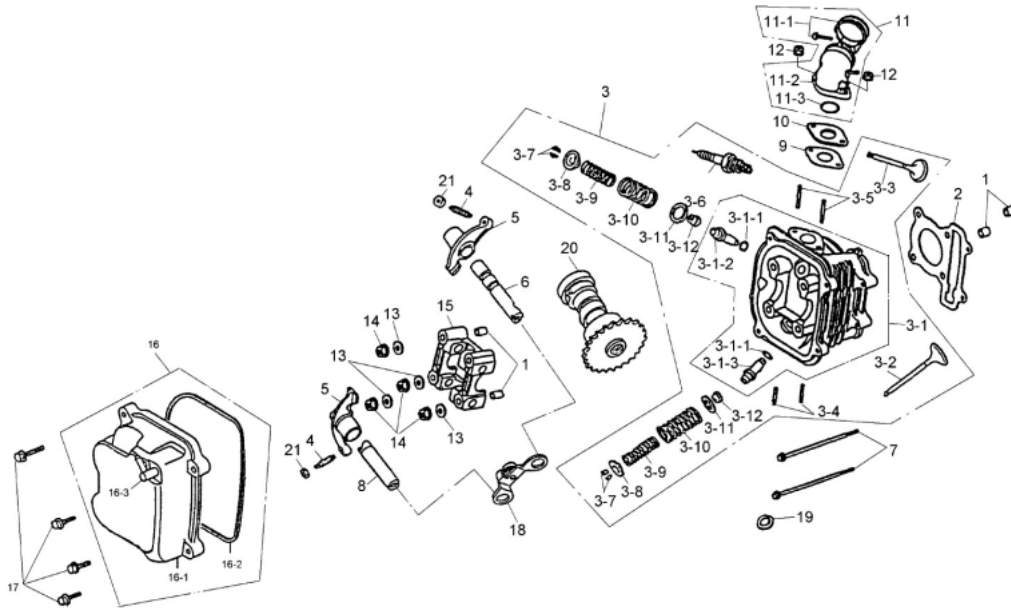

ITEM	AVAIL	PART NO.	NAME	QTY
05			COVER HEAD, HEAD, CAM SHAFT, VALVE	
05-1		I4301-10140	KNOCK PIN	4
05-2		A2251-A08-0000	GASKET CYLINDER HEAD	1
05-3		A220A-A08-0001	HEAD CYLINDER ASS'Y	1
05-3-1		A2200-A08-0001	HEAD COMP CYLINDER	1
05-3-1-1		I4608-09016	O-RING	2
05-3-1-2		A2237-A04-0000	GUIDE IN VALVE	1
05-3-1-3		A2245-A04-0000	GUIDE EX VALVE	1
05-3-2		A4721-A08-0000	VALVE EXHAUST	1
05-3-3		A4711-A08-0000	VALVE INLET	1
05-3-4		I2900-06016-0A	BOLT, STUD	2
05-3-5		I2900-06050-0A	BOLT, STUD	2
05-3-6		I8000-V30-0000	SPARK PLUG	1
05-3-7		A4781-A04-0000	COTTER, VALVE	4
05-3-8		A4771-A04-0000	RETAINER, VALVE SPRING	2
05-3-9		A4761-A07-0000	SPG VALVE INNER	2
05-3-9		A4761-A07-0000	SPG VALVE INNER	2
05-3-10		A4751-A07-0000	SPG VALVE OUTER	2
05-3-11		I4104-16508	WASHER	2
05-3-12		A2209-A04-0000	SEAL VALVE STEM	2
05-4		I0012-A04-0000	SCREW ADJUSTING	2
05-5		A4431-A07-0001	ARM VALVE ROCKER	2
05-6		A4450-A04-0000	SHAFT COMP IN ROCKET ARM	1
05-7		I6001-06100-0H	FLANGE BOLT, HEX.	2
05-8		A4452-A04-0000	SHAFT EX ROCKET ARM	1
05-9		A6201-A04-0000	GASKET CARB INSULATOR	1
05-10		A6211-A04-0000	INSULATOR CARB	1
05-11		A711A-V30-0000	PIPE ASSY INLET	1
05-11-1		A7256-V30-0000	AIR CLEANER CONNECTING TUBE	1
05-11-2		A7110-A07-9000	PIPE COMP INLET	1
05-11-3		I4608-27020	O-RING	1
05-12		I4050-0600G	NUT	2
05-13		I4101-08523	WASHER	4
05-14		I4050-08075-0H	NUT HEXAGON HEAD	4
05-15		A2211-A04-0000	HOLDER CAM SHAFT	1
05-16		A230A-A04-0000	COVER ASSY HEAD CYLINDER	1
05-16-1		A2301-A04-0001	COVER HEAD CYLINDER	1

05-16-2		A2391-A04-0000	GASKET COVER HEAD CYLINDER	1
05-16-3		A2305-A04-0000	JOINT COMP BREATHER	1
05-17		I6001-06025-0C	FLANGE BOLT, HEX.	4
05-18		A4150-A04-0000	PLATE COMP STOPPER	1
05-19		A8291-A04-0000	GASKET EXHAUST PIPE	1
05-20		A4100-A07-0001	SHAFT COMP CAM	1
05-21		I4001-050K0	NUT HEX	2

## 6. FAN COVER · SHROUD

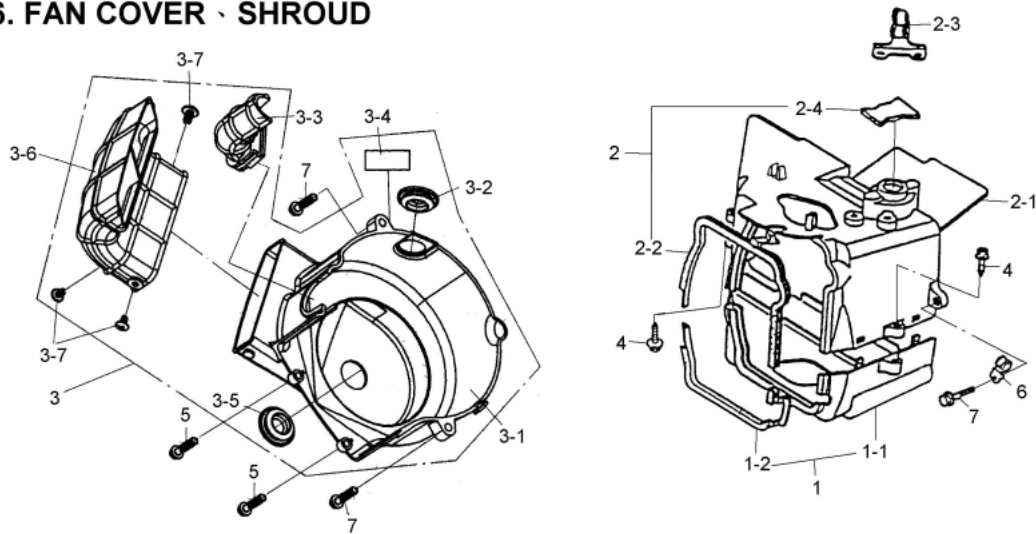

ITEM	AVAIL	PART NO.	NAME	QTY
06			FAN COVER, SHROUD	
06-1		A9620-A07-0001	SHROUD COMP A	1
06-1-1		A9621-V30-0000	SHROUD A	1
06-1-2		A9637-V30-0000	NUT SPRING	1
06-1-3		A9625-A04-0000	SEAL SHROUD A	1
06-2		A963A-V30-0001	SHROUD B ASSY	1
06-2-1		A9630-V30-0000	SHROUD B COMP	1
06-2-2		A9636-V30-0000	CLAMPER CABLE	1
06-2-3		A9637-V30-0000	NUT SPRING	1
06-2-4		A9633-A04-0000	GROMMET SHROUD(B)	1
06-2-4		A9633-A04-0000	GROMMET SHROUD(B)	1
06-2-5		A9635-A04-0000	SEAL SHROUD B	1
06-3		A961A-V30-0000	FAN COVER ASSY	1
06-3-1		A9610-V30-0000	COVER COMP FAN	1
06-3-2		G0529-A04-0000	GROMMET SHROUD	1
06-3-3		A9615-A04-0000	DUCT CARBURETOR COOLING	1
06-3-4		H7541-V30-0000	LABEL OIL CAP	1
06-3-5		G0529-V30-0000	GROMMET SHROUD	1
06-3-6		A9616-V30-0000	DUCT INLET	1
06-3-7		I3902-304B0	SELF-TAPPING SCREW	3
06-4		I3904-316B0	TAPPING SCREW, HEX.	2
06-5		I3500-05025-0G	SCREW, PAN	2
06-6		A1385-V30-0000	CLAMPER CARB DRAIN TUBE	1
06-7		I6001-06025-0C	FLANGE BOLT, HEX.	3

### 7.DRIVEN PULLEY(C.V.T)

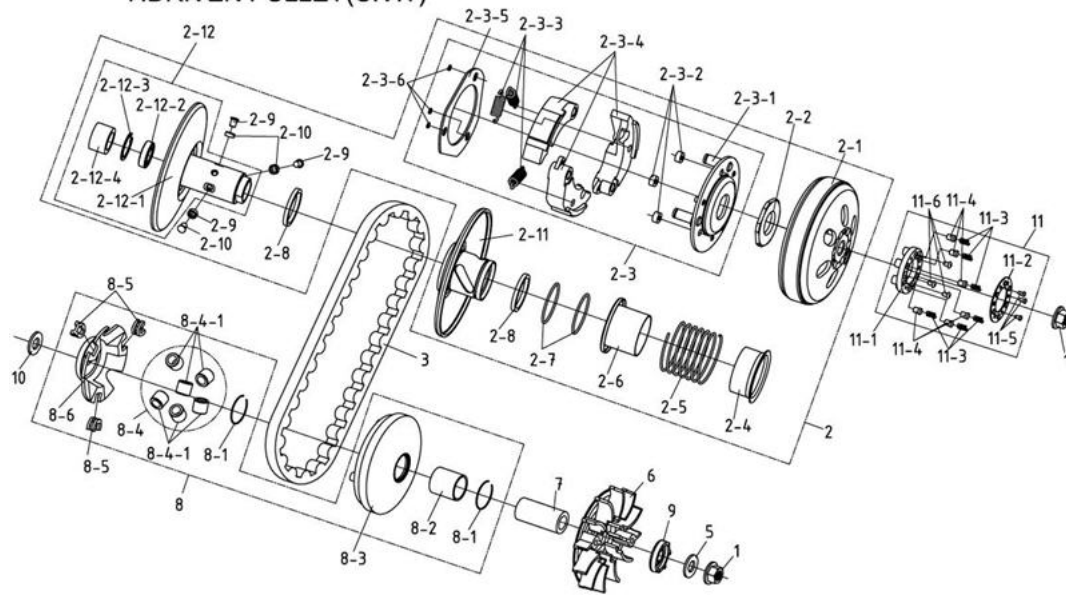

ITEM	AVAIL	PART NO.	NAME	QTY
07			DRIVEN RULLEY (CVT)	
07-1		I4050-12110-0H	FLANGE NUT, HEX.	2
07-2		B301A-V30-9000	PULLEY ASSY DRIVEN	1
07-2	N	B301A-V30-0000	PULLEY ASSY DRIVEN	1
07-2-1		B2101-A04-9000	OUTER CLUTCH	1
07-2-1		B2101-A04-0000	OUTER CLUTCH	1
07-2-2		I0202-A04-9000	NUT SPECIAL	1
07-2-2		I0202-A04-0000	NUT SPECIAL	1
07-2-3		B2300-V30-0000	PLATE COMP DRIVE	1
07-2-3-1		B2350-A04-0000	PLATE COMP DRIVE	1
07-2-3-2		B2804-A04-0000	RUBBER CLUTCH DAMPER	3
07-2-3-3		B2401-A04-0000	SPRING CLUTCH	3
07-2-3-4		B2530-V30-0000	WEIGHT SET CLUTCH	1
07-2-3-5		B2361-A04-0000	PLATE CLUTCH SIDE	1
07-2-3-6		I4540-0701A	CIRCLIP	3
07-2-4		B3238-A04-0000	COLLAR SPRING	1
07-2-5		B3233-A08-0000	SPRING DRIVER FACE	1
07-2-6		B3237-A04-0000	COLLAR SEAL	1
07-2-7		I1351-A04-0000	O-RING PINION CAP	2
07-2-8		I1211-A04-0000	SEAL DRIVEN FACE (34x41x4)	2
07-2-9		B3225-A04-0000	PIN ROLLER GUIDE	3
07-2-10		B3226-A04-0000	ROLLER GUIDE	3
07-2-11		B3220-A04-0000	FACE COMP MOVABLE DRIVEN	1
07-2-12		B3200-A04-0000	FACE COMP DRIVEN	1
07-2-12-1		B3210-A04-0000	FACE DRIVEN	1
07-2-12-2		I6140-6902LU3	BEARING, BALL, RADIAL	1
07-2-12-3		I4520-28000	CIR CLIP IN	1
07-2-12-4		I1120-202918	BEARING, NEEDLE	1
07-3		B3100-A07-0000	BELT DRIVE	1
07-5		I3002-15024-1C	WASHER (25x15.2x2.5T)	1
07-6		B2102-A14-0000	FACE DRIVE	1
07-7		B2105-A04-0000	BOSS DRIVE FACE	1
07-8		B2110-A08-0000	FACE ASSY. MOVABLE DRIVE	1
07-8-1		I4601-28000	CLIP	1
07-8-2		B2112-A04-0000	BOSS FACE MOVABLE DRIVE	1
07-8-3		B2111-A04-0000	FASE COMP MOVABLE DRIVE	1
07-8-4		A0001-A08-0000	ROLLER COMP WEIGHT	1
07-8-4-1		B2121-A08-0000	ROLLER SET WEIGHT	6
07-8-5		B2132-A04-0000	PIECE SLIDE	3

07-8-6		B2131-A04-0000	PLATE RAMP	1
07-9		B8211-A14-0002	RATCHET KICK STARTER	1
07-10		I4104-15104	WASHER	1
07-11		B3240-V30-0000	DISK CLUTCH FRICTON COMP	1
07-11-1		B3241-V30-0000	STOPPER PUMP	1
07-11-2		B3242-V30-0000	STOPPER	1
07-11-3		B3243-V30-0000	CLUTCCH	6
07-11-4		B3244-V30-0000	BRAKE LINING	6
07-11-5		I3501-V30-0000	SCREW BUTTON HEAD CAP	3
07-11-6		I3502-V30-0000	SCREW BUTTON HEAD CAP	3

## 8. TRANSMISSION

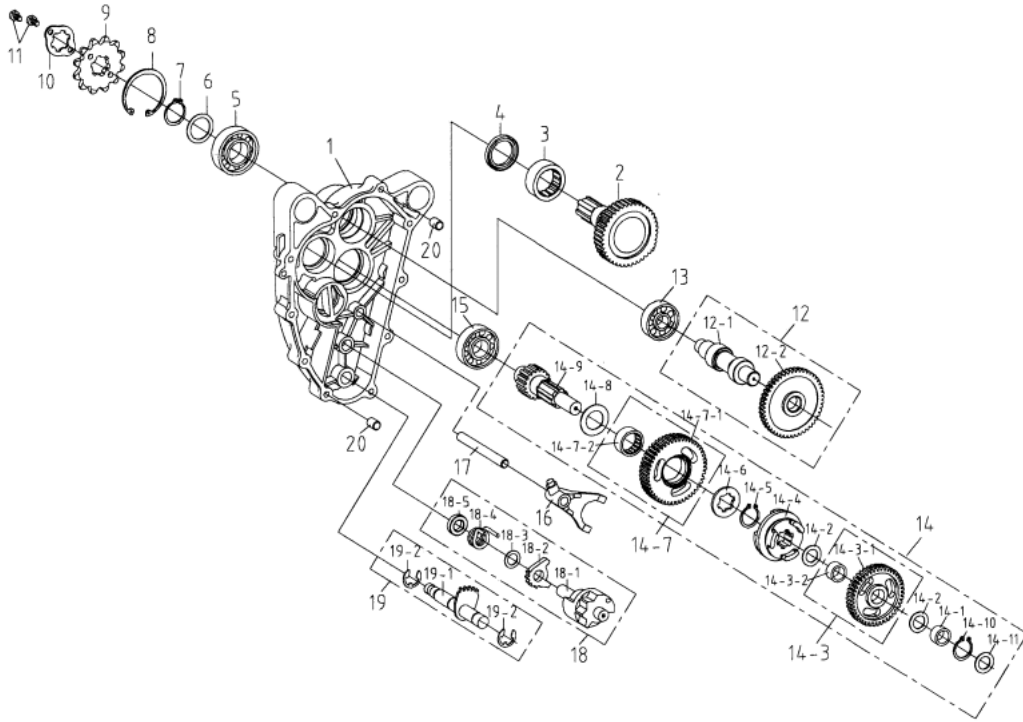

ITEM	AVAIL	PART NO.	NAME	QTY
08			TRANSMISSION	
08-1		B1300-V30-0900	COVER MISSION	1
08-2		B3430-V30-0000	FINAL SHAFT COMP (40T)	1
08-3		I1130-304217	BEARING, NEEDLE	1
08-4		I1201-V30-0000	OIL SEAL	1
08-5		I6150-62053-10	BEARING, BALL, RADIAL	1
08-6		I4104-25210	WASHER	1
08-7		I4510-25000	CIRCLIP EX	1
08-8		I4520-52000	CIRCLIP IN	1
08-9		B3801-V30-0001	SPROCKET DRIVE	1
08-10		B3811-V30-0000	PLATE FIXING	1
08-11		I2201-06010-0C	BOLT	2
08-12		B3420-V30-9000	COUNTER SHAFT COMP	1
08-12-1	N	B3421-V30-0000	SHAFT COUNTER	1
08-12-2	N	B3422-V30-9000	GEAR COUNTER	1
08-13		I6100-63020	BRG RADIAL BALL	1
08-14		B3250-V30-9000	SHAFT GEAR SHIFT COMP	1
08-14-1	N	B3213-V30-0001	COLLAR SHAFT	1
08-14-2	N	I4104-15110	WASHER	2
08-14-3	N	B3440-V30-0000	SPUR GEAR ASSY	1
08-14-3-1	N	B3441-V30-9000	GEAR SPUR	1
08-14-3-2	N	B8113-V30-9000	BUSH	1
08-14-4	N	B3481-V30-0000	RATCHET SHIFT	1
08-14-5	N	I4510-22000	CIRCLIP EX	1
08-14-6	N	I0454-22030	WASHER B SPINE	1
08-14-7	N	B3460-V30-0000	REVERSE GEAR ASSY	1
08-14-7-1	N	B3461-V30-0000	GEAR REVERSE	1
08-14-7-2	N	I1130-223013	BEARING, NEEDLE	1
08-14-8	N	I4104-22010	WASHER	1
08-14-9	N	B3251-V30-9000	SHAFT MAIN TRANSMISSION	1
08-14-10		I4540-15000	CIR CLIP	1
08-14-11		I4104-15010A	WASHER	1
08-15		I6100-62043	BEARING, BALL, RADIAL	1
08-16		B4231-V30-0000	FORK SHIFT	1
08-17		B4241-V30-0000	SHAFT GEAR SHIFT	1
08-18		B4300-V30-0000	DRUM COMP GEAR SHIFT	1
08-18-1	N	B4301-V30-0000	DRUM GEAR SHIFT	1
08-18-2	N	B4302-V30-0000	GEAR SHAFT RETURN	1
08-18-3	N	I4104-13110	WASHER	1

08-18-4	N	B4303-V30-0000	SPRING GEAR SHAFT RETURN	1
08-18-5	N	B4304-V30-0000	COLLAR SHAFT	1
08-19		B461A-V30-0000	SPINDLE ASSY SHIFT	1
08-19-1		B4610-V30-0000	SPINDLE COMP SHIFT	1
08-19-2		I4540-1201A	CIRCLIP	2
08-20		I4301-10140	KNOCK PIN	2

## 9. GEAR SHAFT LEVER · SAFETY SWITCH

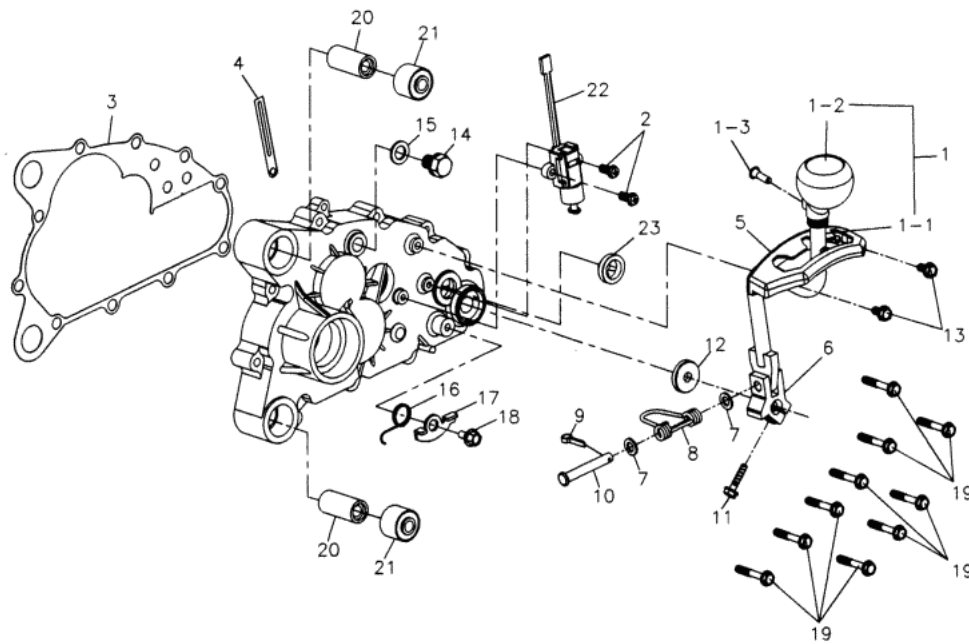

ITEM	AVAIL	PART NO.	NAME	QTY
09			GEAR SHAFT LEVER, SAFETY SWITCH	
09-1		B4640-V30-9000	SHIFT COMP ROD	1
09-1-1		B4641-V30-0001	SHAFT ROD	1
09-1-2		B4642-V30-9000	HANDLE PLASTICS	1
09-1-3		I3600-06020-0G	SCREW FLAT	1
09-2		I3892-05016-0C	SCREW WASHER	2
09-3		B1395-V30-0000	GASKET MISSION COVER	1
09-4		C2963-A09-0000	CLAMPER PULSER CORD	1
09-5		B4622-V30-0000	FIXING SUPPORT CATCH	1
09-6		B4643-V30-0000	FIXED SUPPORT ROD SHIFT	1
09-7		I4104-08515	WASHER	2
09-8		B4644-V30-0000	SPRING ROD SHIFT	1
09-9		I4201-46195	SPLIT PIN	1
09-10		B4645-V30-0000	PIN ROD SHIFT	1
09-11		I5701-06025-0C	FLANGE BOLT, HEX.	1
09-12		I1206-A00-0000	OIL SEAL	1
09-13		I5801-06012-0C	FLANGE BOLT, HEX.	2
09-14		I2800-12015-0C	BOLT, HEX.	1
09-15		I4104-12120	WASHER	1
09-16		B4624-V30-0000	SPRING TRANSMISSION PLATE	1
09-17		B4623-V30-0000	PLATE TRANSMISSION	1
09-18		I5701-06010-0C	BOLT , HEXAGON HEAD	1
09-19		I5701-06040-0C	BOLT , HEXAGON HEAD	10
09-20		A8254-V30-0000	BOSS (B)	2
09-21		A1103-V30-0000	RUBBER BUSH ENGINE HANGER	2
09-22		C510A-V30-0000	BACK POSITION SW	1
09-23		A1332-A09-0000	GAUGE OIL LEVEL	1

## 10.AIR CLEANER

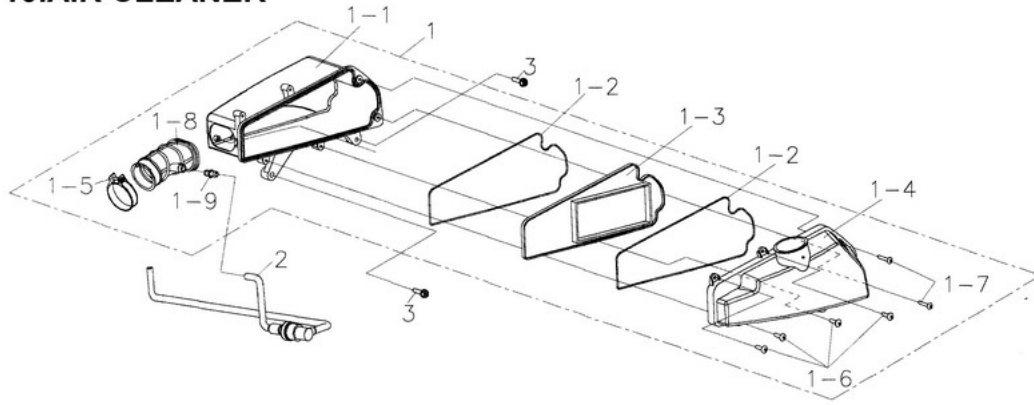

ITEM	AVAIL	PART NO.	NAME	QTY
10			AIR CLEANER	
10-1		A720A-V30-0001	AIR CLEANER ASSY	1
10-1-1		A7230-V30-0001	CASE AIR / C	1
10-1-2		A7214-A11-0000	SEAL AIR CLEANER COVER	2
10-1-3		A7205-A12-0000	FILTER PAPER ASSY.	1
10-1-4		A7231-V30-0001	COVER AIR/C	1
10-1-5		A7256-A04-0000	BAND AIR CLEANER CONNECTING TUBE	1
10-1-6		I3903-320B0	SELF-TAPPING SCREW	4
10-1-7		I3903-430B0	SELF-TAPPING SCREW	2
10-1-8		A7253-V30-0000	AIR CLEANER CONNECTING TUBE	1
10-1-9		A7364-A11-0000	B TUBE BERATHER	1
10-2		A736A-V30-9001	CATCH TANK ASSY	1
10-3		I5701-06025-0C	FLANGE BOLT, HEX.	2

# 11. CARBURETOR

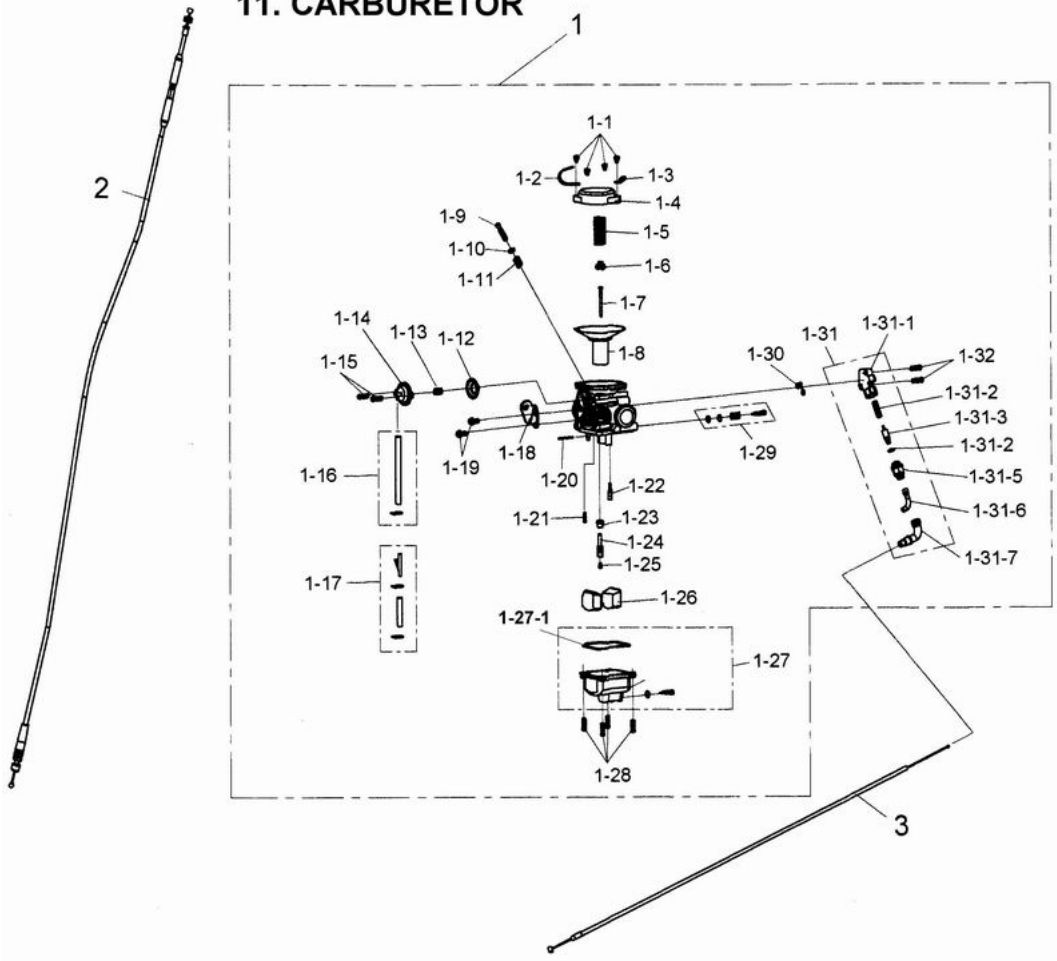

ITEM	AVAIL	PART NO.	NAME	QTY
11			CARBURETOR (MANUAL CHOKE WITH THREE THR	

# 11. CARBURETOR

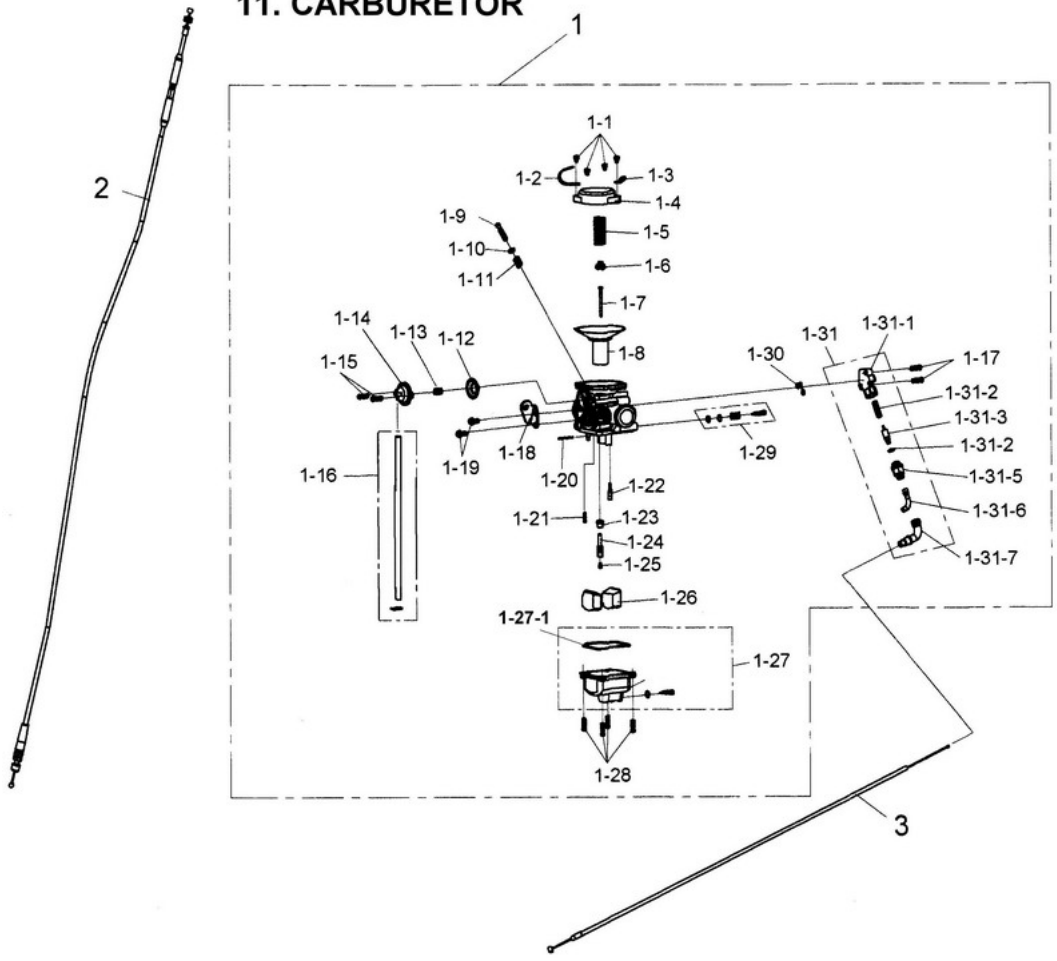

ITEM	AVAIL	PART NO.	NAME	QTY
11			CARBURETOR (MANUAL CHOKE WITHOUT THREE	

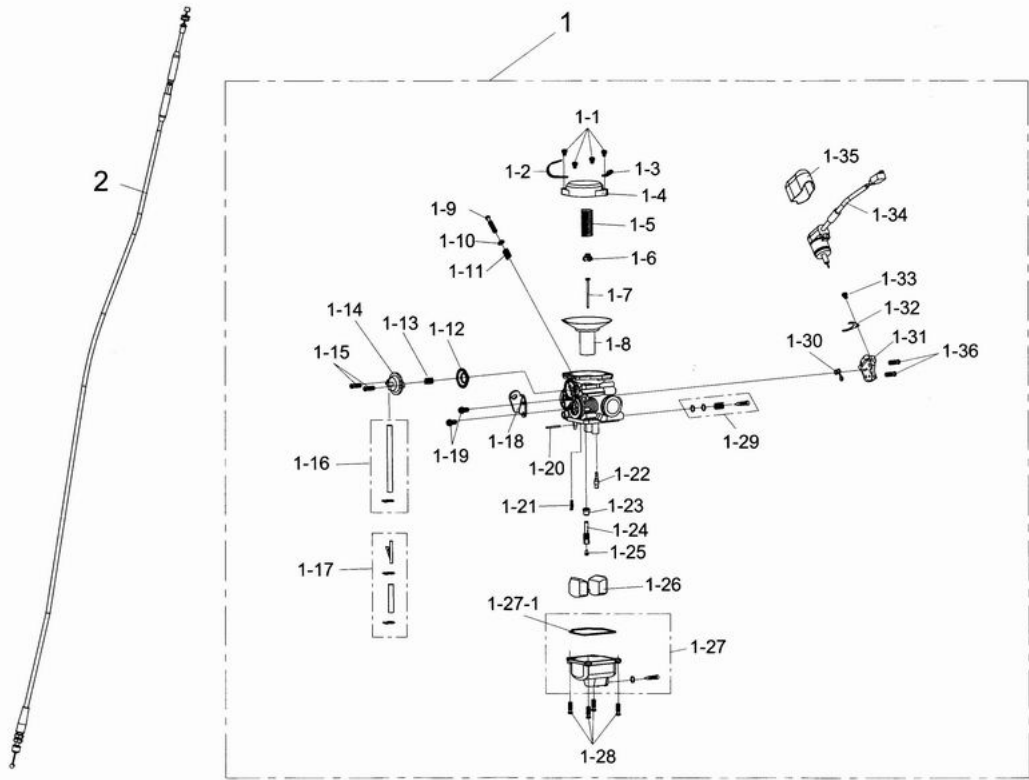

ITEM	AVAIL	PART NO.	NAME	QTY
11			CARBURETOR (AUTO-BY/STARTER)	
11-1		A610A-V30-0000	CARBURETOR ASSY.	1
11-1-1		AC001-M1	SCREW	4
11-1-2		KAB44010-M1	PLATE FIXED PISTON COVER (B)	1
11-1-3		KAB43910-M1	PLATE FIXED PISTON COVER (A)	1
11-1-4		KAB43820-M1	VACUUM PISTON COVER ASSY	1
11-1-5		KAB73710-M1	PISTON SPRING	1
11-1-6		KAB43610-M1	SPRING PLACE	1
11-1-7		KAB73320-M1	JET NEEDLE	1
11-1-8		KAB43440-M1	VACUUM PISTON COMP	1
11-1-9		KAB41710-M1	THROTTLE ADJUSTING	1
11-1-10		A1046-M1	WASHER	1
11-1-11		KAB41810-M1	AIR SPRING	1
11-1-12		KAB41930-M1	A.C.V DIAPHRAGM ASSY	1
11-1-13		KAB42010-M1	A.C.V SPRING	1
11-1-14		KAB40410-M1	A.C.V COVER	1
11-1-15		AC036-M1	SCREW+WASHER	2
11-1-16		A0004-V30-0000	BEAR TUBE COMP	1
11-1-17		A0005-V30-0000	THREE THROUGH TUBE COMP	1
11-1-18		KAB41610-M1	CABLE FIXED SEAT	1
11-1-19		AC034-M1	SCREW	2
11-1-20		KAB42410-M1	FLOAT PIN	1
11-1-21		KAB4CC20-M1	NEEDLE VALVE ASSY.	1
11-1-22		KAB73010-M1	SLOW JET	1
11-1-23		KAB42910-M1	NEEDLE JET	1
11-1-24		KAB73110-M1	NEEDLE JET HOLDER	1
11-1-25		KAB83104	MAIN JET ( # 104)	1
11-1-26		KAB42310-M1	FLOAT ASSY.	1
11-1-27		A0003-V30-0000	CARB CHAMBER COMP	1
11-1-27-1		KAB45710-M1	CHAMBER O-RING	1
11-1-28		AC033-M1	SCREW	4
11-1-29		KAB40G04-M1	AIR ADJUSTING SCREW ASSY.	1
11-1-30		KAB47210-M1	OIL SEAL	1
11-1-31		KAB40310-M1	AUTO-BY/STARTER SEAT	1
11-1-32		KAB45810-M1	PLATE AUTO-BY/STARTER	1
11-1-33		AC037-M1	SCREW+WASHER	1
11-1-34		KAB47610-M1	AUTO-BY/STARTER	1
11-1-35		KAB47611-M1	AUTO-BY/STARTER COVER	1

11-1-36		I3895-05016-1H	SCREW PAN	2
11-2		A7910-V30-0000	CABLE ASSY THROT	1

## 12. OIL COOLER

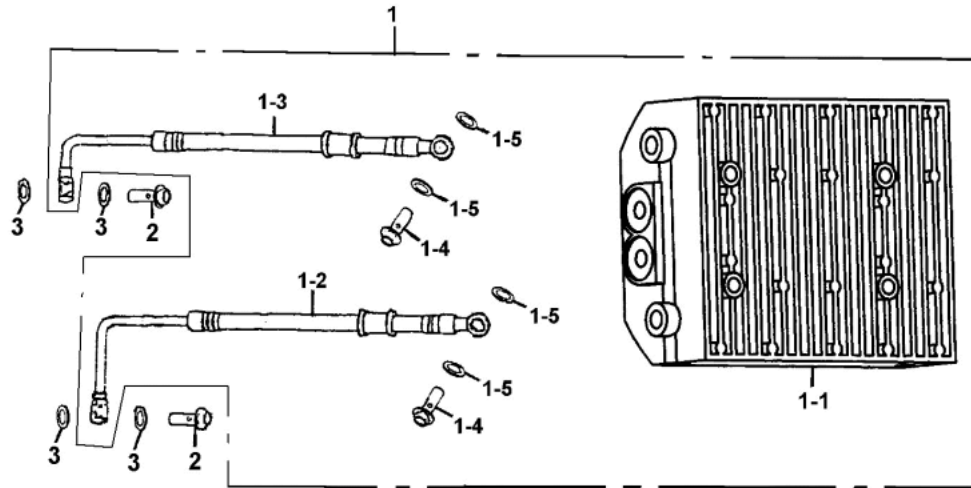

ITEM	AVAIL	PART NO.	NAME	QTY
12			OIL COOLER	
12-1		I902A-V30-9001	COOLER ASSY OIL	1
12-1-1		I9020-V30-9900	COOLER ASSY OIL	1
12-1-2		A9121-V30-0002	OIL HOSE COMP INLET	1
12-1-3		A9122-V30-0002	OIL HOSE COMP OUTLET	1
12-1-4		I0002-V30-0000	BOLT OIL PASS	2
12-1-5		I4104-12514	WASHER	4
12-2		I0002-V30-0000	BOLT OIL PASS	2
12-3		I4104-12514	WASHER	4

# 13. ENGINE

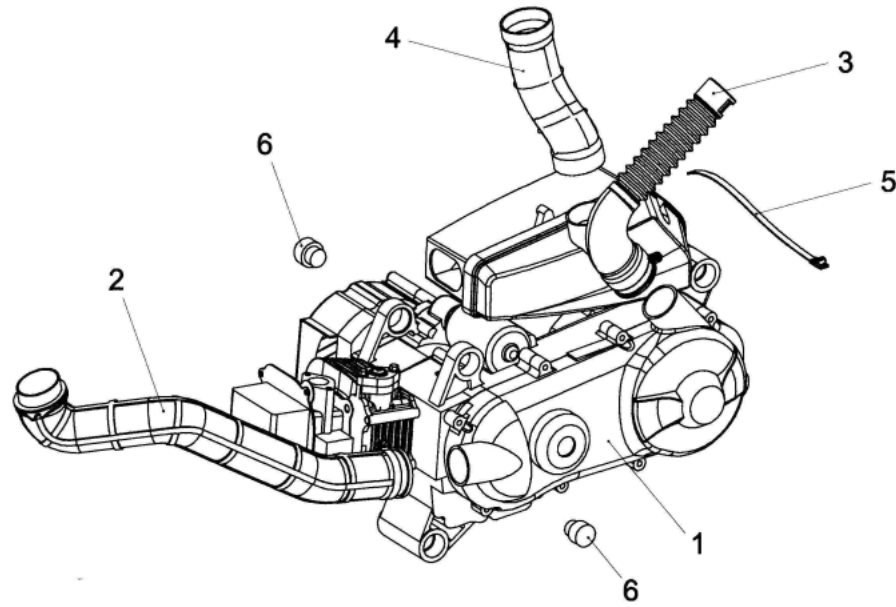

ITEM	AVAIL	PART NO.	NAME	QTY
13			ENGINE	
13-1		AA000-V30-8302	ENGINE	1
13-2		B0100-FIA0-0000	INLET TUBE , CVT	1
13-3		B0200-FIA0-0000	EXH TUBE , CVT	1
13-4		A7215-V30-0000	DUCT AIR CLEANER IN	1
13-5		H3936-5AA0-0000	WIRE CLAMP	1
13-6		A1105-FIA0-0000	ENGINE RUBBER PLUG	2

# 14. MUFFLER

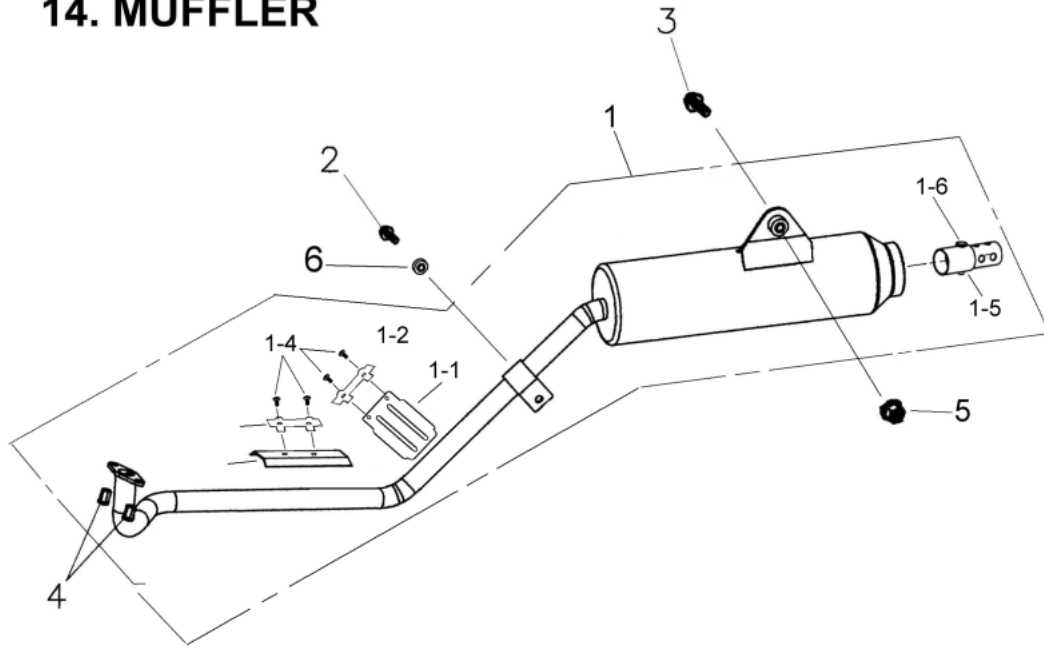

ITEM	AVAIL	PART NO.	NAME	QTY
14			MUFFLER	
14-1		A830A-FIA0-9000	EXHAUST PIPE ASSY.	1
14-1-1		A830B-FIA0-1000	DRIVE CHAIN COVER	1
14-1-2		A830C-FIA0-1000	ANTI-LOOSEN STRIP	2
14-1-3		A830D-FIA0-0000	FRONT EXHAUST PIPE COVER	1
14-1-4		A830F-FIA0-0000	BOLT WASHER	4
14-1-5		A8303-FIA0-0000	SPARK ARRESTER	1
14-1-6		A830G-FIA0-0000	SCREW	1
14-2		I7507-FIA0-0000	BOLT, HEX.	1
14-3		I0149-08036-01	BOLT, FLANGE	1
14-4		I0179-06850	NUT	2
14-5		I5611-08200	HEX. FLANGE NUT, SAFETY	1
14-6		I3016-08018-1G	WASHER	1

# 14. MUFFLER(U.S)

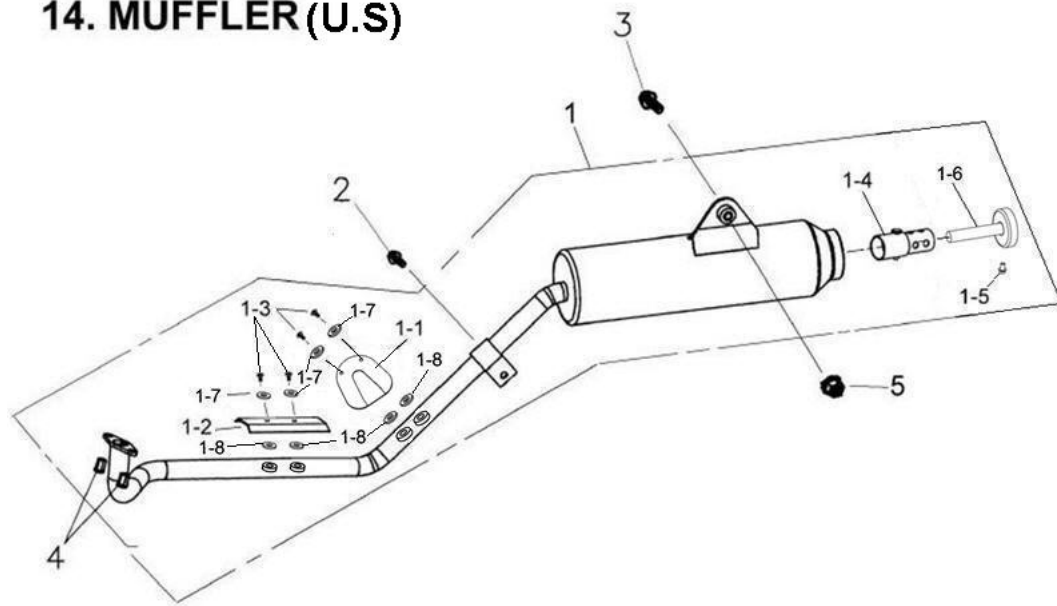

ITEM	AVAIL	PART NO.	NAME	QTY
14			MUFFLER(U.S)	

# 15.FRAME

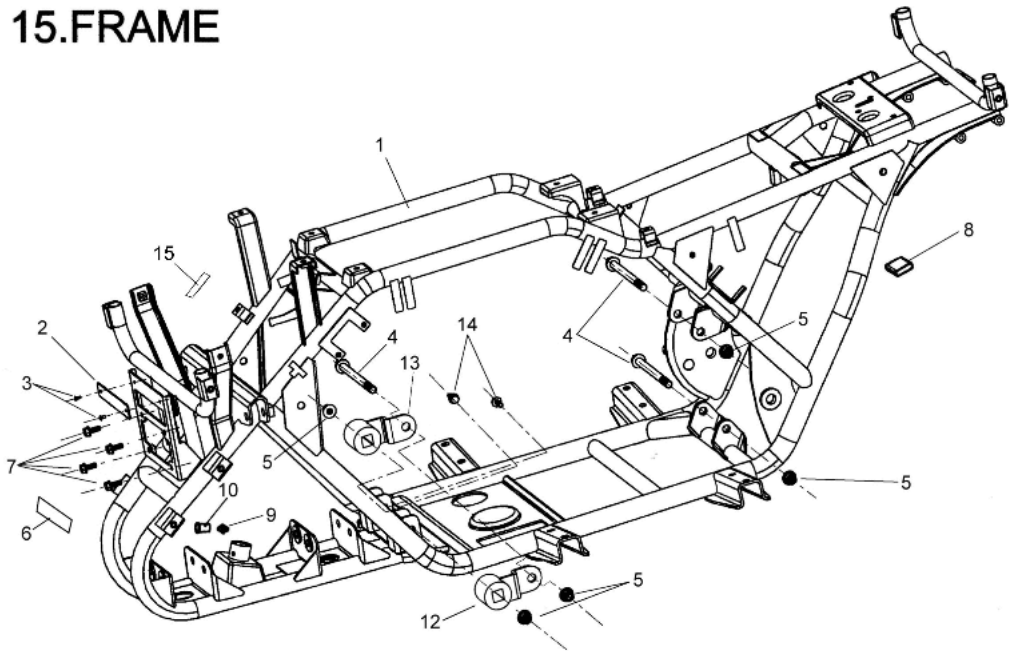

ITEM	AVAIL	PART NO.	NAME	QTY
15			FRAME	
15-1		E0100-FIB0-1000	FRAME COMP.	1
15-2	N	E0101-5EA0-0000	FRAME NUMBER PLATE	1
15-3		H750A-5BA1-0000	NAIL, PULL	2
15-4		E0351-5EA0-0000	FLANGE BOLT, HEX.	3
15-5		I5611-10200	HEX. FLANGE NUT, SAFETY	5
15-6		F4309-5EA0-0000	STICKER, MFD.	1
15-7		I2501-06080-0B	BOLT,HEXAGON HEAD	4
15-8		G7223-5EB0-0000	RUBBER PAD	1
15-9		I6600-06000	GREASE VALVE	0
15-10		E0209-5EA0-9000	CAP, GREASE VALVE	1
15-12		E0350-FIA0-0000	ENGINE SUSPENSION ASSY. ,LEFT	1
15-13		E0353-FIA0-0000	ENGINE SUSPENSION ASSY. ,RIGHT	1
15-14		E0352-FIA0-0000	BOLT, QUAD	2

# 16. FENDER

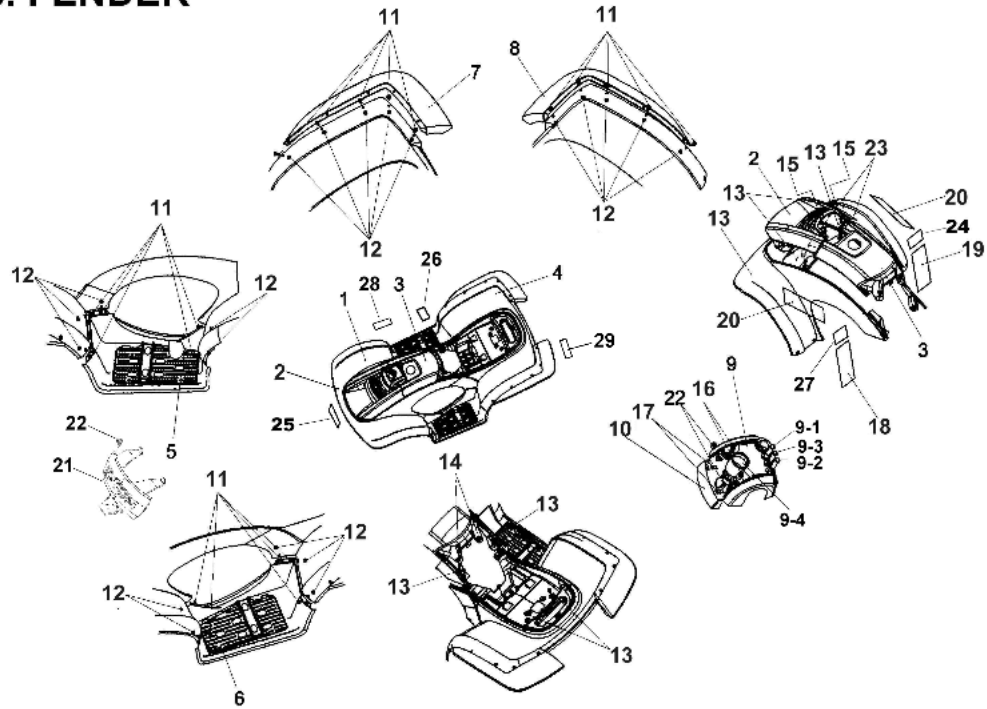

ITEM	AVAIL	PART NO.	NAME	QTY
16			FENDER	
16-1		F4300-FIB0-4200	FRONT FENDER (RED)	1
16-1		F4300-FIB0-0C00	FRONT FENDER (CAMO)	1
16-1		F4300-FIB0-2500	FRONT FENDER (GREEN)	1
16-1		F4300-FIB0-0700	FRONT FENDER(SILVER)	1
16-1		F4300-FIB0-5400	FRONT FENDER(BLUE)	1
16-2		F4301-FIA0-0800	FRONT CENTRAL COVER(BLACK)	1
16-3		F4302-FIA0-0800	REAR CENTRAL COVER (BLACK)	1
16-4		H3500-FIA0-4200	REAR FENDER(RED)	1
16-4		H3500-FIA0-5400	REAR FENDER(BLUE)	1
16-4		H3500-FIA0-0700	REAR FENDER(SILVER)	1
16-4		H3500-FIA0-2500	REAR FENDER(GREEN)	1
16-4		H3500-FIA0-0C00	REAR FENDER(CAMO)	1
16-5		H3520-FIA0-0800	FOOTREST, RIGHT	1
16-6		H3620-FIA0-0800	FOOTREST, LEFT	1
16-7		H3720-FIA0-0800	TRIM,REAR RIGHT	1
16-8		H3820-FIA0-0800	TRIM,REAR LEFT	1
16-9		E320A-FIA0-0800	COVER, HANDLE BAR	1
16-9-1		C3101-FIA0-0000	INDICATE(RED)	1
16-9-2		C3102-FIA0-0000	INDICATE(BLUE)	1
16-9-3		C3103-FIA0-0000	INDICATE(GREEN)	1
16-9-4		C7801-FIA0-0000	METER,FUEL LEVER	1
16-10		E3206-FIA0-0800	FRONT PLATE,HANDLE BAR COVER	1
16-11		E0117-9EA0-0000	SCREW, TRUSS	20
16-12		I5611-06200-0G	HEX. FLANGE NUT, SAFETY	20
16-13		I0119-06821	BOLT, HEX.	8
16-14		I0149-06035	FLANGE BOLT, HEX.	2
16-15		I8310-FIA0-0000	PLASTIC SCREW	2
16-16		I8556-06020	SCREW, PAN HEAD	2
16-17		I4603-04000-5C	NUT, SPRING	2
16-18		H7101-FIA0-9000	STICKER, WARNING (PASSENGER)	1
16-19		H7102-FIA0-9000	STICKER, WARNING (Y-16)	1
16-20		H7103-FIB1-0000	STICKER,CHALLENGER CXL150	1
16-21		F4303-FIB0-0800	HAED LIGHT COVER	1
16-22		I2804-04010-5C	TAPPING SCREW, TRUSS	3
16-23		I7707-04016	TAPPING SCREW, TRUSS	2
16-24		H7102-5EA1-9000	STICKER,CE	1

16-26		H7129-FIA0-0000	STICKER,INDICATE GEAR	1
-------	--	-----------------	-----------------------	---

## 17. SWING ARM

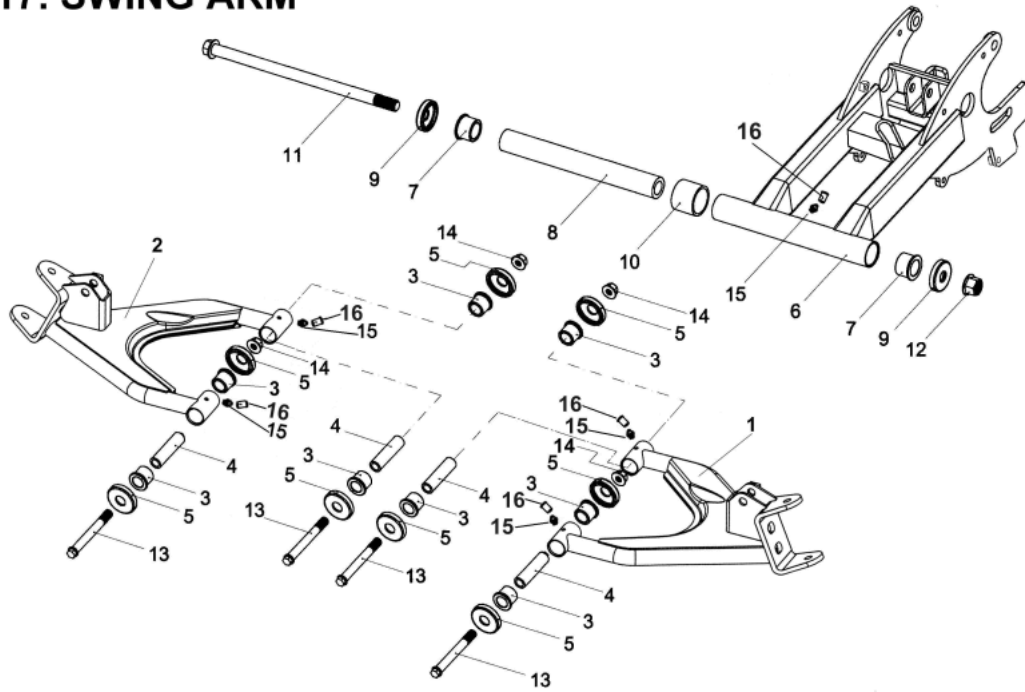

ITEM	AVAIL	PART NO.	NAME	QTY
17			SWING ARM	
17-1		E0200-FIA0-1000	ARM, SUSPENSION, L.H.	1
17-2		E0210-FIA0-1000	ARM, SUSPENSION, R.H.	1
17-3		E0201-FIA0-0000	BUSH, ARM SUSPENSION	8
17-4		E0209-FIA0-0000	SPACER	4
17-5		E2205-4HA0-0000	SWING ARM SEAL COVER (25.4)	8
17-6		E220A-FIB0-9001	SWING ARM COMP.	1
17-7		E2208-5EA0-0000	SWING ARM OIL LINER	2
17-8		E2209-FIA0-0000	SPACER	1
17-9		E2205-5EA0-0000	OIL SEAL	2
17-10		E2202-FIA0-0000	RUBBER SLEEVE	1
17-11		E2201-FIA0-0000	FLANGE BOLT, HEX.	1
17-12		I5611-14200	HEX. FLANGE NUT, SAFETY	1
17-13		I0149-10080	FLANGE BOLT, HEX.	4
17-14		I5611-10200	HEX. FLANGE NUT, SAFETY	4
17-15		I6600-06000	GREASE VALVE	5
17-16		E0209-5EA0-9000	CAP, GREASE VALVE	5

# 18. SEAT

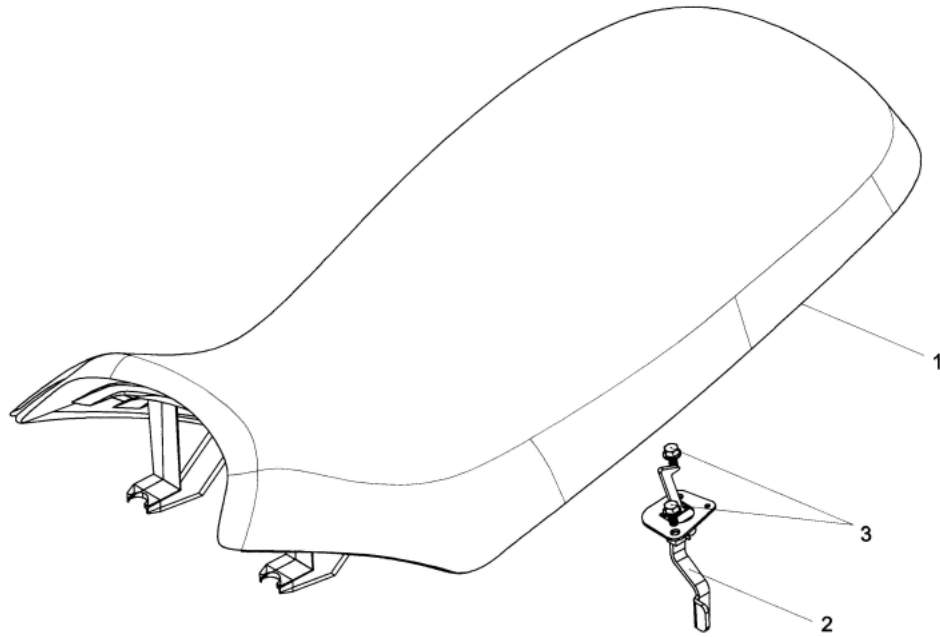

ITEM	AVAIL	PART NO.	NAME	QTY
18			SEAT	
18-1		G7200-FIC0-0000	SEAT ASSY	1
18-2		G7201-FIA0-0000	SEAT LOCK	1
18-3		I0149-06012	FLANGE BOLT, HEX.	2

# 19. FUEL TANK, OIL TANK

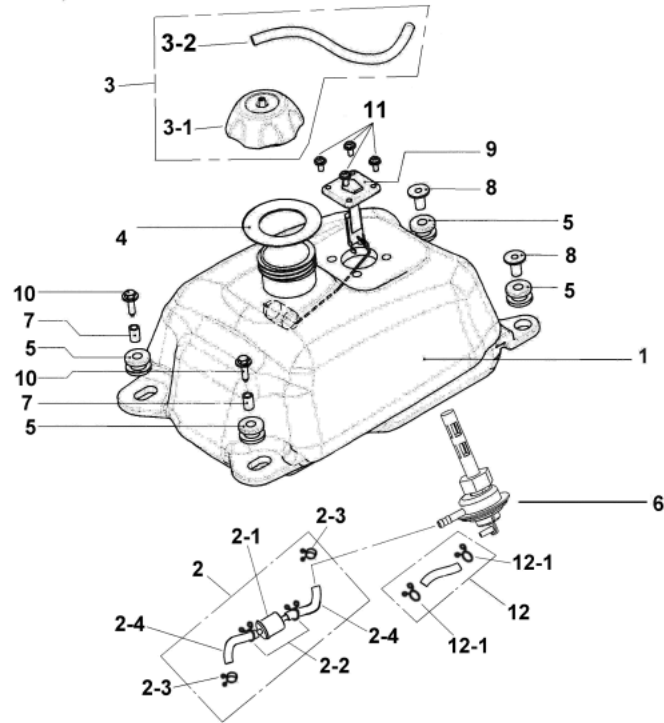

ITEM	AVAIL	PART NO.	NAME	QTY
19			FUEL TANK	
19-2		A751A-FIA0-1000	FUEL FILTER ASSY.	1
19-2-1		A7519-FIA0-1000	FUEL FILTER	1
19-2-2		A7516-5EA0-0000	CLIP(A)	2
19-2-3		A7517-FIA0-0000	CLIP	2
19-2-4		A7514-FIA0-0000	FUEL TUBE(A)	2
19-3		A762A-9FA0-0000	FUEL TANK CAP ASSY.	1
19-3-1		A7620-9FA0-0000	FUEL TANK CAP	1
19-3-1		A7620-9FA0-0000	FUEL TANK CAP	1
19-3-2		A7621-9FA0-0000	TUBE, RUBBER	1
19-3-2		A7621-9FA0-0000	TUBE, RUBBER	1
19-4		A7622-9FA0-0000	RUBBER PAD, FUEL TANK CAP	1
19-5		A7510-FIA0-0000	FUEL TANK RUBBER PAD	4
19-6		A6701-FIA0-0000	FUEL COCK ASSY.	1
19-7		A7511-FIA0-0000	RUBBER INSULATOR	2
19-8		A7512-FIA0-0000	FUEL TANK GASKET SPACER	2
19-9		C780A-FIA0-0000	METER FUEL LEVER	1
19-10		I7507-06225	BOLT, HEX.	2
19-11		I0200-50160	CROSS BOLT, HEX.	4
19-12		A751B-FIA0-0000	VACUUM TUBE COMP	1
19-12-1		A7518-FIA0-0000	CLIP	2
19-12-1		A7518-FIA0-0000	CLIP	2

# 19. FUEL TANK, OIL TANK

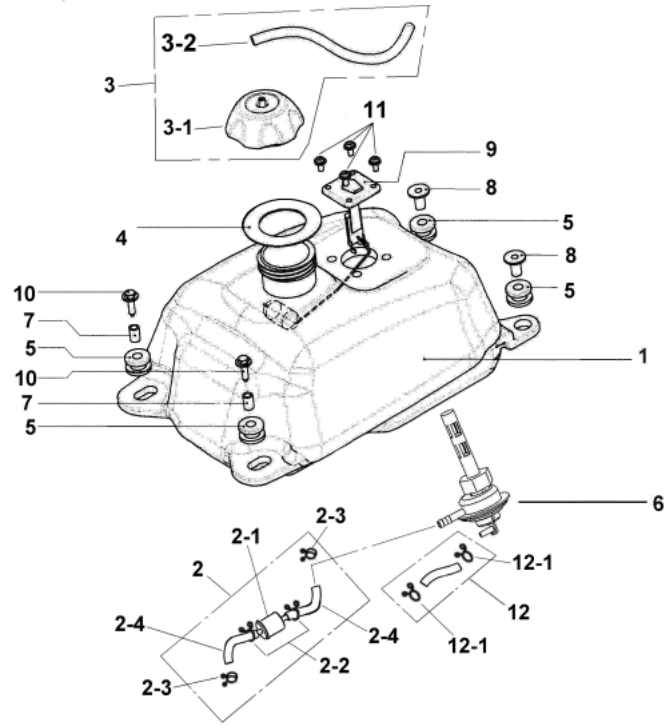

ITEM	AVAIL	PART NO.	NAME	QTY
19			FUEL TANK	
19-1		A7500-FIA0-0000	FUEL TANK COMP	1
19-2		A751A-FIA0-1000	FUEL FILTER ASSY.	1
19-3		A762A-9FA0-0000	FUEL TANK CAP ASSY.	1
19-3-1		A7620-9FA0-0000	FUEL TANK CAP	1
19-3-2		A7621-9FA0-0000	TUBE, RUBBER	1
19-4		A7622-9FA0-0000	RUBBER PAD, FUEL TANK CAP	1
19-5		A7510-FIA0-0000	FUEL TANK RUBBER PAD	4
19-6		A6701-FIA0-0000	FUEL COCK ASSY.	1
19-7		A7511-FIA0-0000	RUBBER INSULATOR	2
19-8		A7512-FIA0-0000	FUEL TANK GASKET SPACER	2
19-9		C780A-FIA0-0000	METER FUEL LEVER	1
19-10		I7507-06225	BOLT, HEX.	2
19-11		I0200-50160	CROSS BOLT, HEX.	4
19-12		A7503-FIA0-0000	VACUUM TUBE COMP	1
19-12-1		I5002-02659	CLIP	2

## 20. SUSPENSION

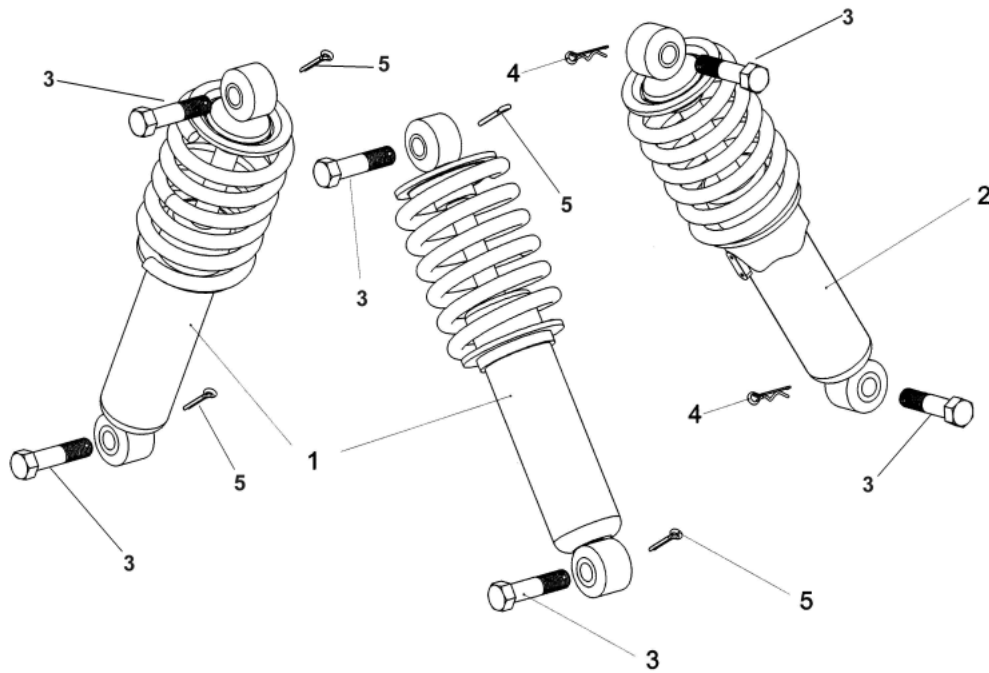

ITEM	AVAIL	PART NO.	NAME	QTY
20			SUSPENSION	
20-1		E1105-FIA0-9000	SUSPENSION	2
20-2		E2400-FIC0-0000	SUSPENSION, REAR	1
20-3		I0102-10040B	FLANGE BOLT, HEX.	6
20-4		I0468-12006	PIN	2
20-5		I9900-25019	PIN, SPLIT	4

## 21. FRONT WHEEL

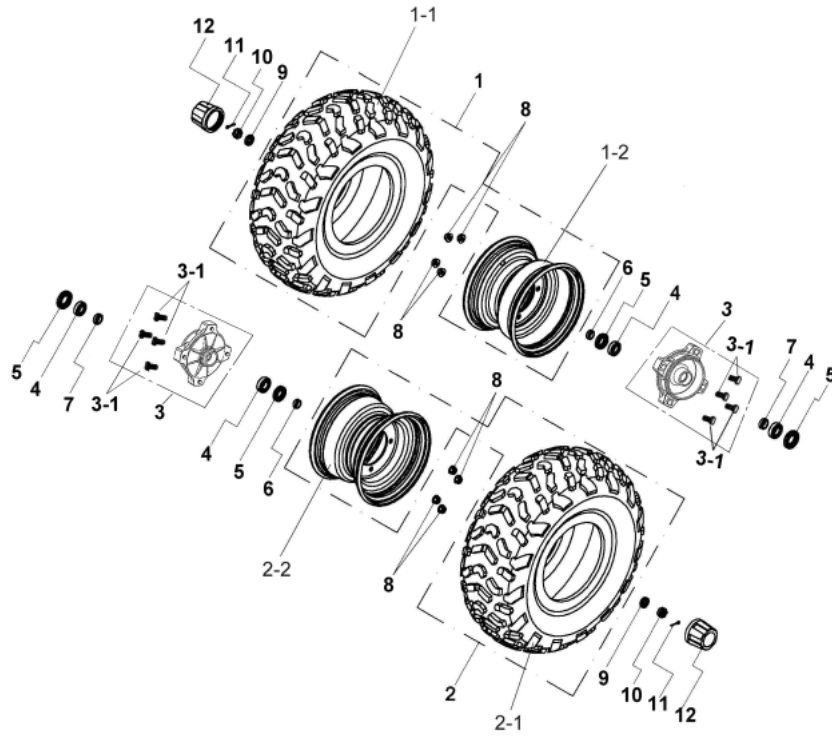

ITEM	AVAIL	PART NO.	NAME	QTY
21			FRONT WHEEL	
21-1		D471A-FIA0-9S00	FRONT WHEEL ASSY.,LEFT(21x7-10)	1
21-1-1		D4710-FIA0-1000	WHEEL TIRE (21x7-10)	1
21-1-2		D4601-FIA0-9S00	WHEEL RIM	1
21-2		D471B-FIA0-9S00	FRONT WHEEL ASSY.,RIGHT(21x7-10)	1
21-2-1		D4710-FIA0-1000	WHEEL TIRE (21x7-10)	1
21-2-2		D4601-FIA0-9S00	WHEEL RIM	1
21-3		D4610-FIA0-9000	BRAKE DRUM, FRONT	2
21-3-1		D4612-9FA0-0000	BOLT,STUD	8
21-4		I6150-60030-10	BEARING, BALL, RADIAL	4
21-5		I1307-24035-10	OIL SEAL	4
21-6		D4621-FIA0-0000	OUTER SPACER	2
21-7		D4620-FIA0-0000	INNER SPACER	2
21-8		D4611-9EA0-0000	FLANGE NUT, HEX.	8
21-9		I9905-14200	WASHER	2
21-10		I5500-14100	CASTLE NUT	2
21-11		I4201-46325	SPLIT PIN	2
21-12		D4609-9FA0-0000	RUBBER CAP	2

## 22. REAR WHEEL

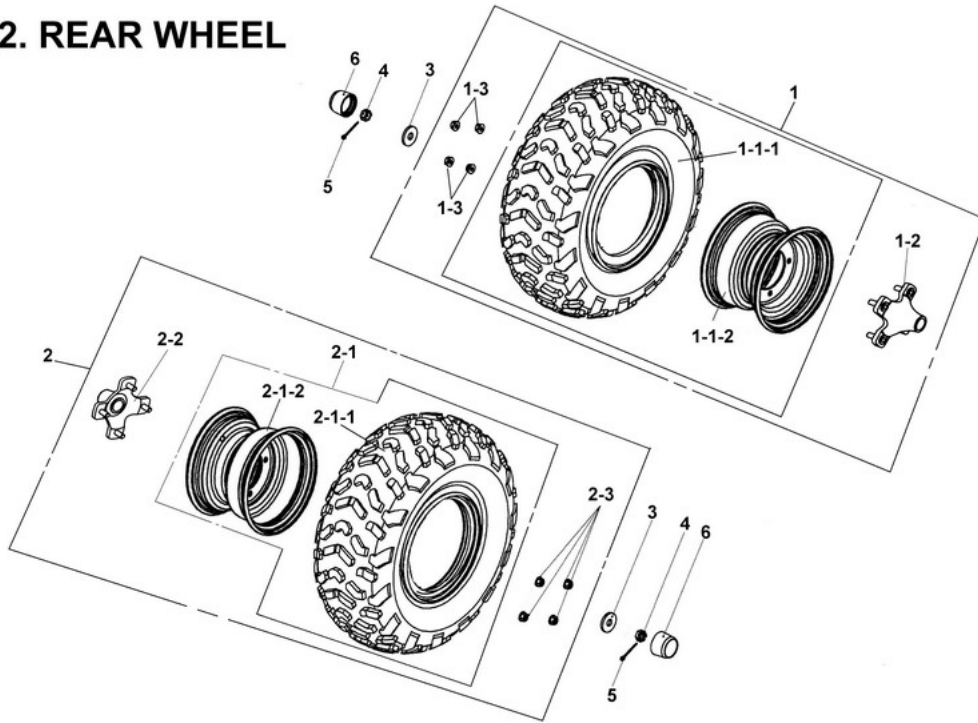

ITEM	AVAIL	PART NO.	NAME	QTY
22			REAR WHEEL	
22-1		D472C-FIA0-8S00	REAR WHELL ASSY.,LEFT(22x10-8)	1
22-1-1		D471C-FIA0-8S00	REAR WHELL COMP.,LEFT(22x10-8)	1
22-1-1-1		D4720-FIA0-9000	WHEEL TIRE (22x10-10)	1
22-1-1-2		D4602-FIC0-9S00	WHEEL RIM (10"x8)	1
22-1-2		D2705-FIA0-9000	SHAFT CONNECTER WITH BOLTS	1
22-1-3		D4611-9EA0-0000	FLANGE NUT, HEX.	4
22-2		D472D-FIA0-8S00	REAR WHELL ASSY.,RIGHT(22x10-8)	1
22-2-1		D471D-FIA0-8S00	REAR WHELL COMP.,RIGHT(22x10-8)	1
22-2-1-1		D4720-FIA0-9000	WHEEL TIRE (22x10-10)	1
22-2-1-2		D4602-FIC0-9S00	WHEEL RIM (10"x8)	1
22-2-2		D2705-FIA0-9000	SHAFT CONNECTER WITH BOLTS	1
22-2-3		D4611-9EA0-0000	FLANGE NUT, HEX.	4
22-3		D2309-5EA0-0000	WASHER	2
22-4		I4012-140H0	CASTLE NUT	2
22-5		I4201-46325	SPLIT PIN	2
22-6		D4609-5EA0-0001	RUBBER CAP	2

## 23. FRONT BRAKE

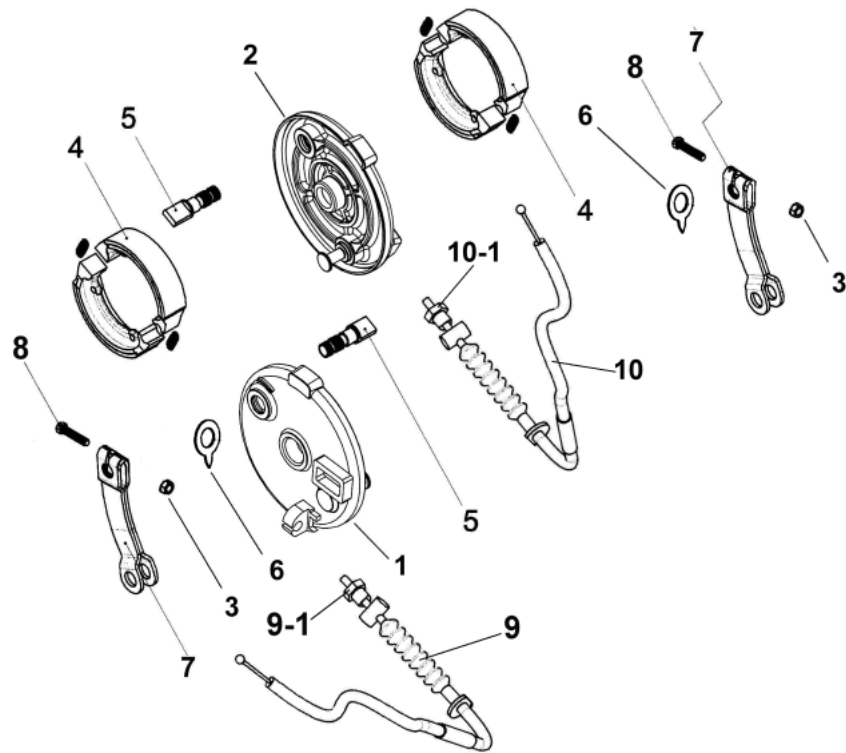

ITEM	AVAIL	PART NO.	NAME	QTY
23			FRONT BRAKE SYSTEM	
23-1		D5351-FIA0-0000	FRONT BRAKE PANEL COMP., LEFT	1
23-2		D5352-FIA0-0000	FRONT BRAKE PANEL COMP., RIGHT	1
23-3		I5707-06500	FLANGE NUT, HEX.	2
23-4		D312A-A04-8000	FRONT BRAKE SHOE COMP. (80)	2
23-5		D5141-FIA0-1000	FRONT BRAKE ARM CAM	2
23-6		D5145-FIA0-0000	BRAKE INDICATOR,FRONT	2
23-7		D5410-FIA0-0000	FRONT BRAKE ARM	2
23-8		I0020-06030	BOLT	2
23-9		E5450-FIA0-1000	CABLE, FRONT BRAKE(LEFT)	1
23-9-1		E5452-FIA0-1000	NUT,ADJUSTING	1
23-9-1		E5452-FIA0-1000	NUT,ADJUSTING	1
23-10		E5451-FIA0-1000	CABLE, FRONT BRAKE(RIGHT)	1
23-10-1		E5452-FIA0-1000	NUT,ADJUSTING	1
23-10-1		E5452-FIA0-1000	NUT,ADJUSTING	1

## 24. REAR BRAKE (HYDRAULIC DISC BRAKE)

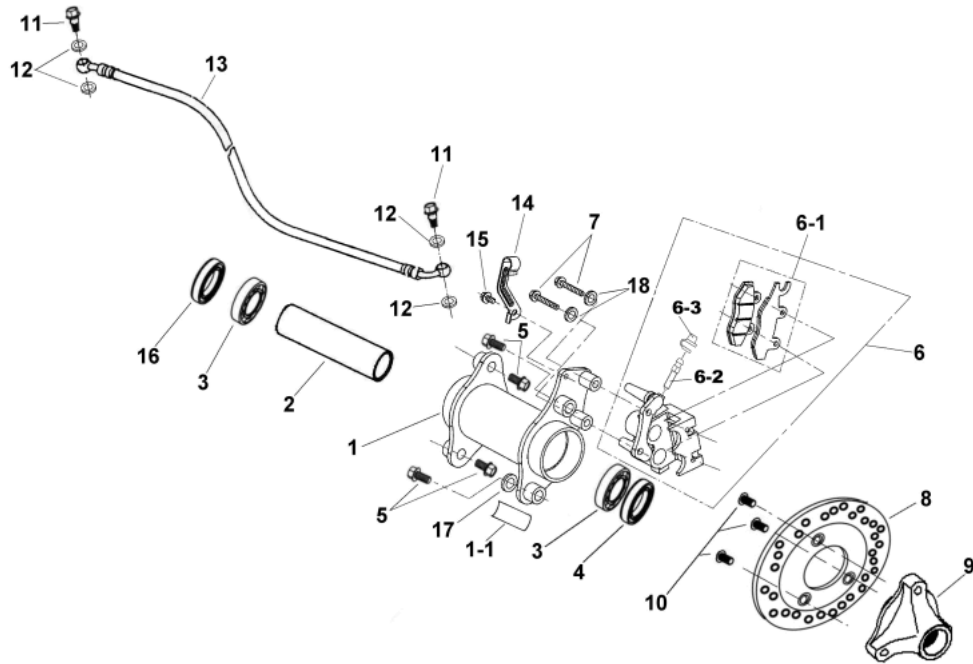

ITEM	AVAIL	PART NO.	NAME	QTY
24			REAR BRAKE (HYDRAULIC DISC BRAKE)	
24-1		D2310-FIA0-1000	BEARING SEAT ASSY., REAR WHEEL AXLE	1
24-1-1		H7106-FIA0-0000	WARNING STICKER , CHAIN	1
24-2		D2311-FIA0-0000	SPACER	1
24-3		I6100-6007LLU	BEARING	2
24-4		D2315-FIA0-0000	OIL SEAL	1
24-5		I0141-12036-01	FLANGE BOLT, HEX.	4
24-6		G7130-BCA0-0000	BRAKE CALLIPER	1
24-6-1		G7131-BCA0-0000	BRAKE SHOE COMP	1
24-6-2		G7132-BCA0-0000	BOLT LEAKAGE	1
24-6-3		G7133-BCA0-0000	CAP LEAKAGE	1
24-7		I0105-08035	BOLT FLANGE	2
24-8		D3520-FIA0-0000	BRAKE DISK	1
24-9		D3251-FIA0-0000	BRAKE DISK MOUNTING SEAT	1
24-10		I0110-10811	BOLT, SOCKET	3
24-11		I0401-10034	FLANGE BOLT, HEX.	2
24-12		I0201-10118	WASHER	4
24-13		D3210-FIA0-0000	BRAKE OIL TUBE	1
24-14		G7111-BCA0-0000	BRAKE FUEL TUBE, CLIP	1
24-15		I0149-06012	FLANGE BOLT, HEX.	1
24-16		D2313-FIA0-0000	OIL SEAL(48x62x7)	1
24-18		I9901-08100	WASHER, SPRING	2

## 24. REAR BRAKE (DRUM BRAKE)

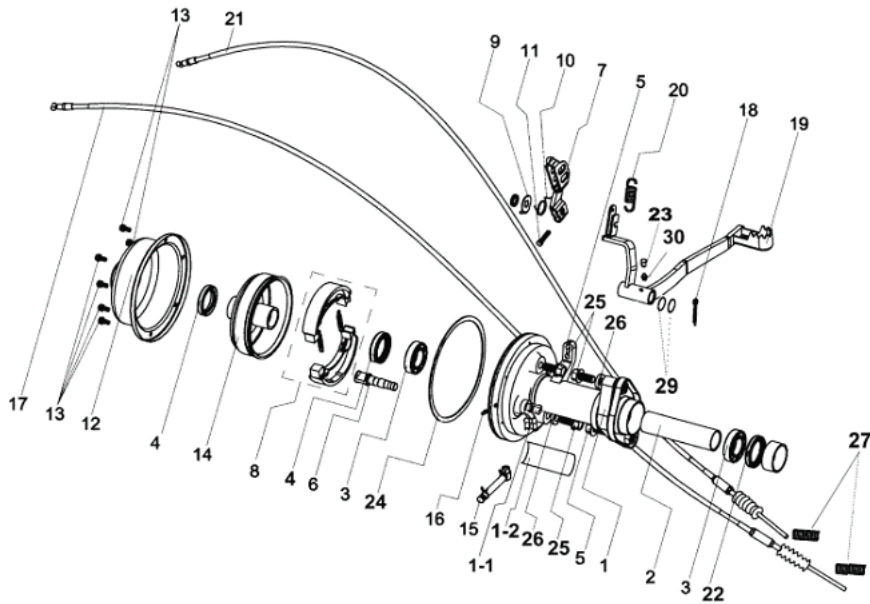

ITEM	AVAIL	PART NO.	NAME	QTY
24			REAR BRAKE (DRUM BRAKE)	
24-1		D231A-FIA0-0000	BEARING SEAT ASSY., REAR WHEEL AXLE	1
24-1-1		D3142-FIA0-0000	REAR SHAFT BRAKE	1
24-1-2		H7106-FIA0-0000	WARNING STICKER , CHAIN	1
24-2		D2311-FIA0-0000	SPACER	1
24-3		I6100-6007LLU	BEARING	2
24-3		I6100-6007LLU	BEARING	2
24-4		D2315-FIA0-0000	OIL SEAL	2
24-5		I0141-12036-01	FLANGE BOLT, HEX.	1
24-6		D3141-FIA0-0010	BRAKE ARM CAM, REAR	1
24-7		D3410-FIA0-0000	BRAKE ARM, REAR	1
24-8		D3120-FIA0-9000	REAR BRAKE SHOE COMP	1
24-9		D3145-FIA0-0000	BRAKE INDICATOR, REAR	1
24-10		D3419-FIA0-0000	RETURN SPRING, REAR	1
24-11		I0020-06030	BOLT	1
24-12		D3615-FIA0-0000	DRUM COVER, REAR	1
24-13		I8557-06012	SCREW WASHER	6
24-14		D3610-FIA0-0000	REAR BRAKE DRUM	1
24-15		D2316-5EA0-0000	DRAIN PIPE ASSY.	1
24-16		D2319-FIA0-0000	PLUG, PURGE HOLE	1
24-17		E3450-FIA0-0000	CABLE, REAR BRAKE	1
24-18		I9900-30032	COTTER PIN(1/8" x 11/4")	1
24-19		E0708-FIA0-0000	BRAKE PEDAL	1
24-20		I5016-5BA1-0000	SIDE STAND SPRING	1
24-21		E0710-FIA0-0000	BRAKE PEDAL CABLE	1
24-22		D2313-FIA0-0000	OIL SEAL(48x62x7)	1
24-23		E0209-5EA0-9000	CAP, GREASE VALVE	1
24-24		D3611-FIA0-0000	O-RING	1
24-25		I0141-12040-01	FLANGE BOLT, HEX.	3
24-26		D2203-5EA0-0000	PLAIN WASHER	2
24-27		D3416-FIA0-0000	SPRING,REAR BRAKE CABLE	2
24-29		D2314-FIA0-0000	O-RING(w2.4xd13.8)	2
24-30		I6600-06000	GREASE VALVE	0

## 25.HANDLE BAR

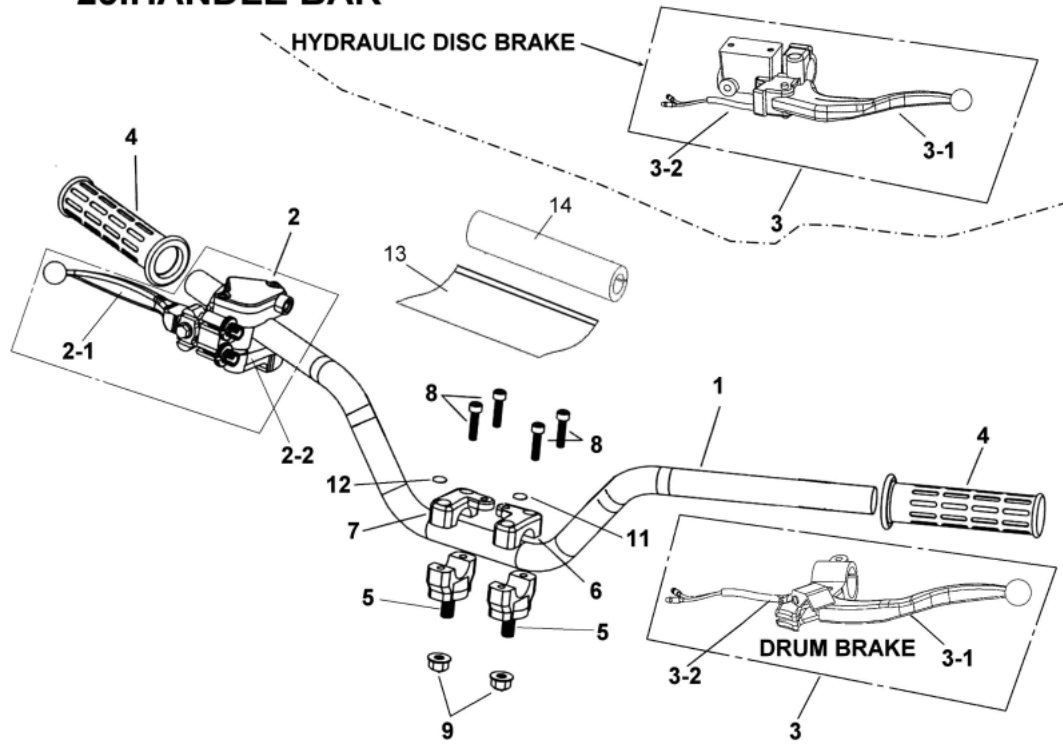

ITEM	AVAIL	PART NO.	NAME	QTY
25			HANDLE BAR (HYDRAULIC DISC BRAKE)	
25-1		E3100-FIA0-9000	HANDLE BAR ASSY.	1
25-2		E3180-FIA0-0000	LEVEL ASSY., RIGHT	1
25-2-1		E3181-5FA0-0000	LEVEL SET,RIGHT	1
25-2-2		E319A-5FA0-0000	LEVEL ACCELERATE	1
25-2-3		E3183-FIA0-0000	COVER LEVER	1
25-2-4		E3188-FIA0-0000	GASKET	1
25-2-5		I8506-04016	SCREW,PAN HEAD	2
25-3		D3200-FIA0-0000	BRAKE MASTER CYLINDER,LEFT	1
25-3-1		D3201-FIA0-0000	LEVEL,LEFT	1
25-3-1		D3201-FIA0-0000	LEVEL,LEFT	1
25-3-2		D3202-FIA0-0000	BRAKE SWITCH ASSY.	1
25-3-2		D3202-FIA0-0000	BRAKE SWITCH ASSY.	1
25-4		E3166-5EA0-0000	GRIP	2
25-5		E3112-5EA0-0000	BOTTOM,HANDLE BAR CLAMP	2
25-6		E3110-5EA0-0000	CAP,HANDEL BAR CLAMP(L)	1
25-7		E3111-5EA0-0000	CAP,HANDEL BAR CLAMP(R)	1
25-8		I0050-06025	BOLT, SOCKET	4
25-9		I5611-10200	HEX. FLANGE NUT, SAFETY	2
25-11		H7111-9FA0-0000	STICKER,HANDLE BAR CLAMP,LEFT	1
25-12		H7112-9FA0-0000	STICKER,HANDLE BAR CLAMP,RIGHT	1
25-13		E3101-5EE0-1000	HANDLE BAR PROTECT (W150x222L)	1
25-14		E3102-5EE0-1000	HANDLE BAR PROTECT FOAM(20x42x220L)	1

## 25.HANDLE BAR

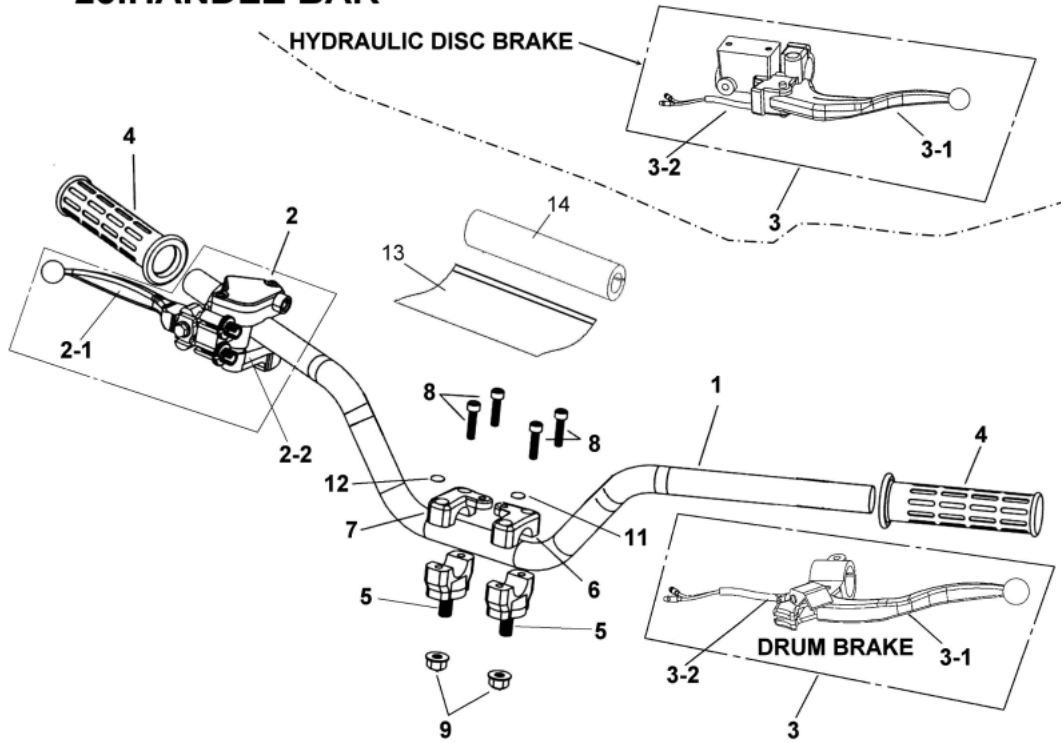

ITEM	AVAIL	PART NO.	NAME	QTY
25			HANDLE BAR (DRUM BRAKE)	
25-1		E3100-FIA0-9000	HANDLE BAR ASSY.	1
25-2		E3180-9FA0-0010	LEVER ASSY., (RIGHT)	1
25-2-1		E3181-9FA0-0000	LEVEL,RIGHT	1
25-2-2		E319A-5EA0-0000	LEVEL ACCELERATE	1
25-3		E3170-FIA0-0000	LEVEL ASSY., LEFT	1
25-3-1		E3171-FIA0-0000	LEVEL,LEFT	1
25-3-2		E3174-5EA0-0000	BARKE SWITH ASSY.	1
25-4		E3166-5EA0-0000	GRIP	1
25-5		E3112-5EA0-0000	BOTTOM,HANDLE BAR CLAMP	1
25-6		E3110-5EA0-0000	CAP,HANDEL BAR CLAMP(L)	1
25-7		E3111-5EA0-0000	CAP,HANDEL BAR CLAMP(R)	1
25-8		I0050-06025	BOLT, SOCKET	1
25-9		I5611-10200	HEX. FLANGE NUT, SAFETY	1
25-11		H7111-9FA0-0000	STICKER,HANDLE BAR CLAMP,LEFT	1
25-12		H7112-9FA0-0000	STICKER,HANDLE BAR CLAMP,RIGHT	1
25-13		E3101-5EE0-1000	HANDLE BAR PROTECT (W150x222L)	1
25-14		E3102-5EE0-1000	HANDLE BAR PROTECT FOAM(20x42x220L)	1

## 26. BUMPER, FOOTREST BAR

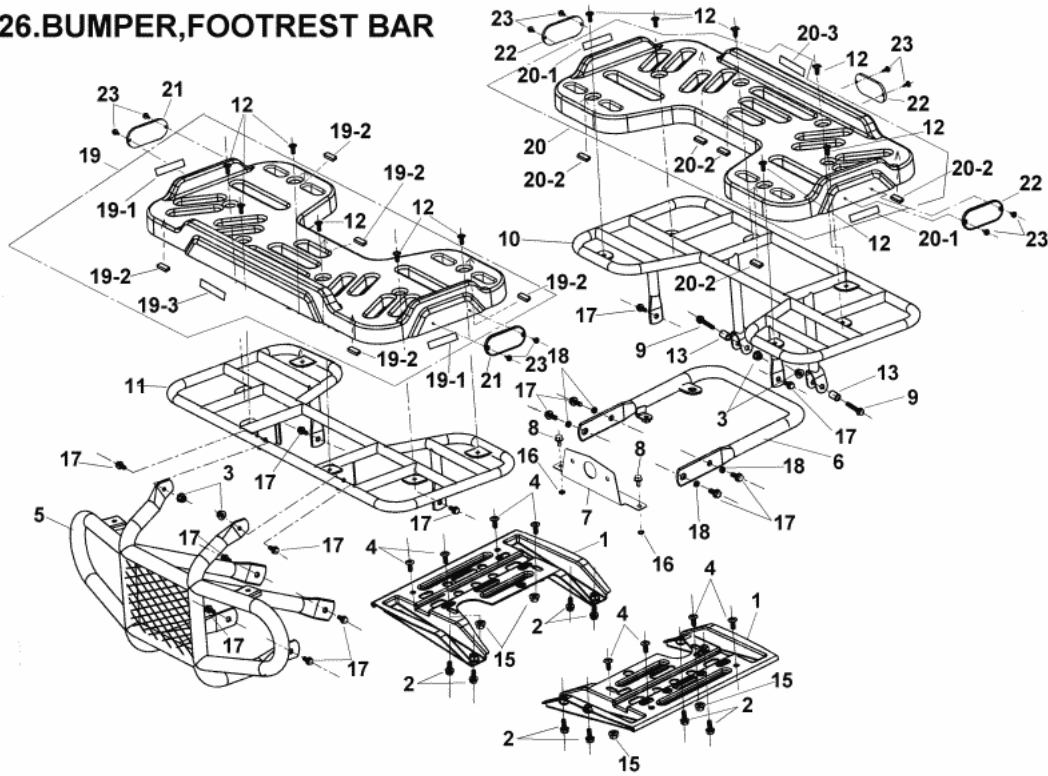

ITEM	AVAIL	PART NO.	NAME	QTY
26			BUMPER, FOOTREST	
26-1		E0700-FIA0-0000	FOOTREST BAR	2
26-2		I7507-FIA0-0000	BOLT, HEX.	8
26-3		I5616-08200	NUTFLANGE CHECK	4
26-4		I0149-06823	SCREW	8
26-5		E0400-FIB0-0000	BUMPER	1
26-6		E0410-FIA0-1000	REAR BAR ASSY.	1
26-7		E0412-FIA0-0000	TAIL LIGHT HOLDER	1
26-8		I0149-06012	FLANGE BOLT, HEX.	2
26-9		I0105-08040	BOLT, FLANGE	2
26-10		E0411-FIB0-0000	REAR PACK	1
26-11		E0413-FIB0-0000	FRONT PACK	1
26-12		E0117-9EA0-0000	SCREW, TRUSS	12
26-13		E0402-9FA0-0000	COLLAR, BUMPER	2
26-15		I5611-06200-0G	HEX. FLANGE NUT, SAFETY	4
26-16		C510C-FIA0-0000	RUBBER PAD	2
26-17		I0149-08016	FLANGE BOLT, HEX.	14
26-18		I9901-08100	WASHER, SPRING	4
26-19		F4000-FIB0-0000	CARRIER COVER FRONT	1
26-19-1		H7116-FIB0-0000	FRONT REFLECTOR, STICKER	2
26-19-2		C1501-FIB0-0000	FOAM-RUBBER STICK	5
26-19-3		H7113-9FB0-0000	CARRIER COVER, STICKER	1
26-20		F4001-FIB0-0000	CARRIER COVER REAR	1
26-20-1		H7117-FIB0-0000	REAR REFLECTOR, STICKER	2
26-20-2		C1501-FIB0-0000	FOAM-RUBBER STICK	5
26-20-3		H7113-9FB0-0000	CARRIER COVER, STICKER	1

## 27. REAR WHEEL AXLE

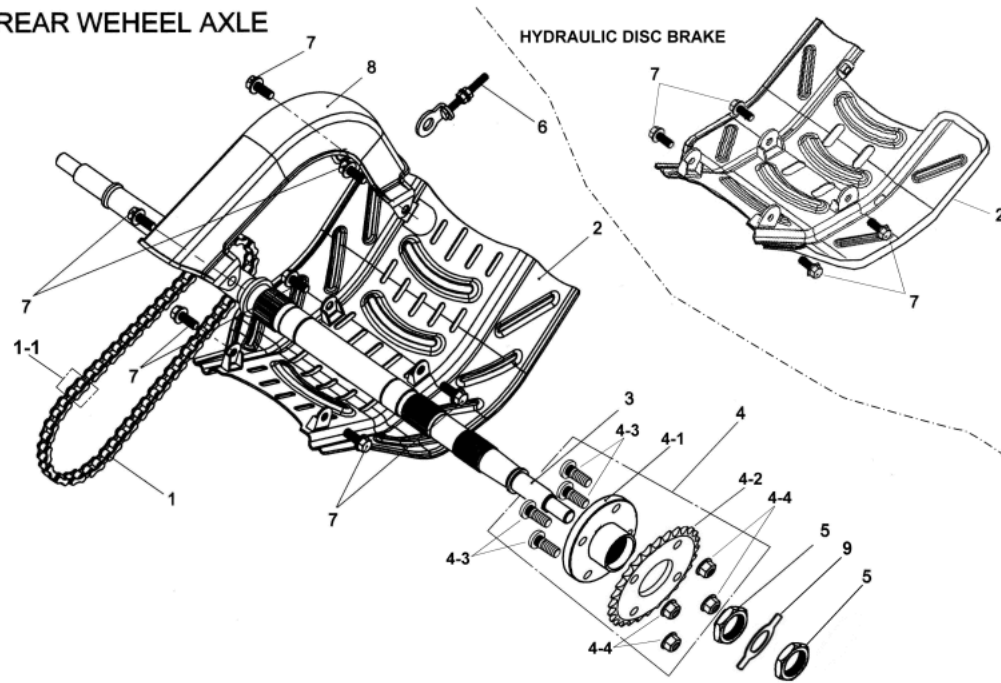

ITEM	AVAIL	PART NO.	NAME	QTY
27			REAR WHEEL AXLE	
27-1		D0100-FIB0-0000	DRIVE CHAIN ASSY.	1
27-1-1		D0104-FIC0-0000	MASTERLINK	1
27-2		D0101-FIA0-1000	PROTECT COVER	1
27-3		D2301-5IK0-0000	REAR AXLE	1
27-4		D0110-FIA0-0000	SPROCKET HOLDER, REAR ASSY.	1
27-4-1		D0111-FIA0-0000	SPROCKET HOLDER, REAR(34T)	1
27-4-1		D0111-FIA0-0000	SPROCKET HOLDER, REAR(34T)	1
27-4-2		D1111-FIA0-0000	GEAR(520X34T)	1
27-4-2		D1111-FIA0-0000	GEAR(520X34T)	1
27-4-3		D2706-9EA0-0000	BOLT	4
27-4-3		D2706-9EA0-0000	BOLT	4
27-4-4		I5611-10200	HEX. FLANGE NUT, SAFETY	4
27-4-4		I5611-10200	HEX. FLANGE NUT, SAFETY	4
27-5		D2302-FIA0-0000	NUT REAR WHEEL AXLE(M28x1.5)	2
27-6		D0120-FIA0-0001	CHAIN ADJUSTER COMP.	1
27-7		I0149-08016	FLANGE BOLT, HEX.	7
27-8		D0102-FIA0-0000	DRIVE CHAIN COVER	1
27-9		D2303-GJA0-0000	PLATE FIXED REAR AXLE(USED WITH D2301-GJ)	1

## 28. STEERING

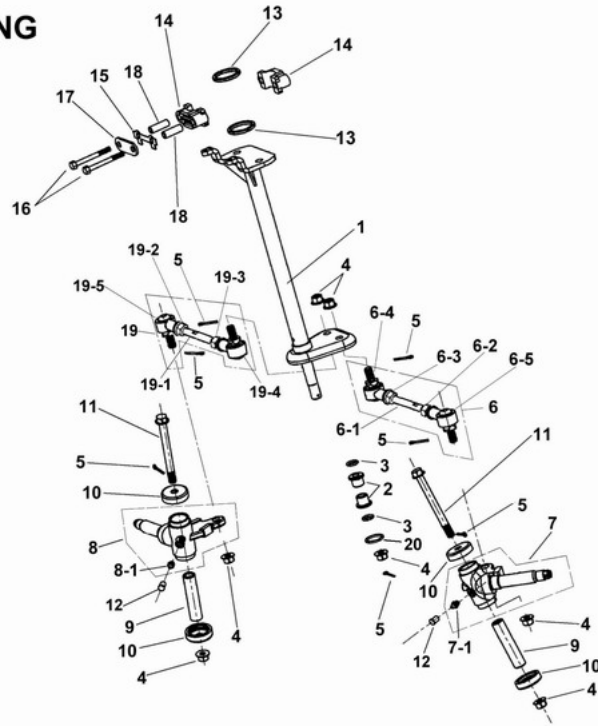

ITEM	AVAIL	PART NO.	NAME	QTY
28			STEERING	
28-1		E3200-FIA0-1000	SHAFT ASSY., STEERING	1
28-2		E3201-FIA0-0000	OIL LINER	2
28-3		E3204-FIA0-0000	O-RING	2
28-4		I5611-10200	HEX. FLANGE NUT, SAFETY	7
28-5		I9900-25019	PIN, SPLIT	7
28-6		E0258-GJA0-0000	STEERING TIE-ROD ASSYLEFT	1
28-6-1		E0251-FIA0-1000	BOLT,STUD	1
28-6-2		E0252-5EA0-0000	NUT (R)	1
28-6-3		E0253-5EA0-0000	NUT (L)	1
28-6-4		E0255-GJA0-0000	UNIVERSAL JOINT(L)	1
28-6-5		E0256-GJA0-0000	UNIVERSAL JOINT(R)	1
28-7		E0205-FIA0-1000	KNUCKLE, LEFT	1
28-7-1		I6600-06000	GREASE VALVE	1
28-8		E0215-FIA0-1000	KNUCKLE, RIGHT	1
28-8-1		I6600-06000	GREASE VALVE	1
28-9		E0211-9FA0-0000	SLEEVE	2
28-10		E0203-9FA0-0000	CAP	4
28-11		I5701-10105-0A	FLANGE BOLT, HEX.	2
28-12		E0209-5EA0-9000	CAP, GREASE VALVE	2
28-13		E3209-FIA0-0000	OIL SEAL(31.8x37.8x4)	2
28-14		E3202-FIA0-0000	HOLDER, STEERING SHAFT	2
28-15		E3203-FIA0-0000	FIX PLATE, STEERING SHAFT	1
28-16		I0020-08060	BOLT, HEX.	2
28-17		E3210-FIA0-0000	HOLDER, STEERING SHAFT PRESSED PLATED	1
28-18		E3208-FIA0-0000	STEERING , COLLAR	2
28-19		E0259-GJA0-0000	STEERING TIE-ROD ASSYRIGHT	1
28-19-1		E0251-FIA0-1000	BOLT,STUD	1
28-19-2		E0252-5EA0-0000	NUT (R)	1
28-19-3		E0253-5EA0-0000	NUT (L)	1
28-19-4		E0255-GJA0-0000	UNIVERSAL JOINT(L)	1
28-19-5		E0256-GJA0-0000	UNIVERSAL JOINT(R)	1
28-20		I4608-09424	O-RING	1

## 29.ELECTRICAL EQUIPMENT

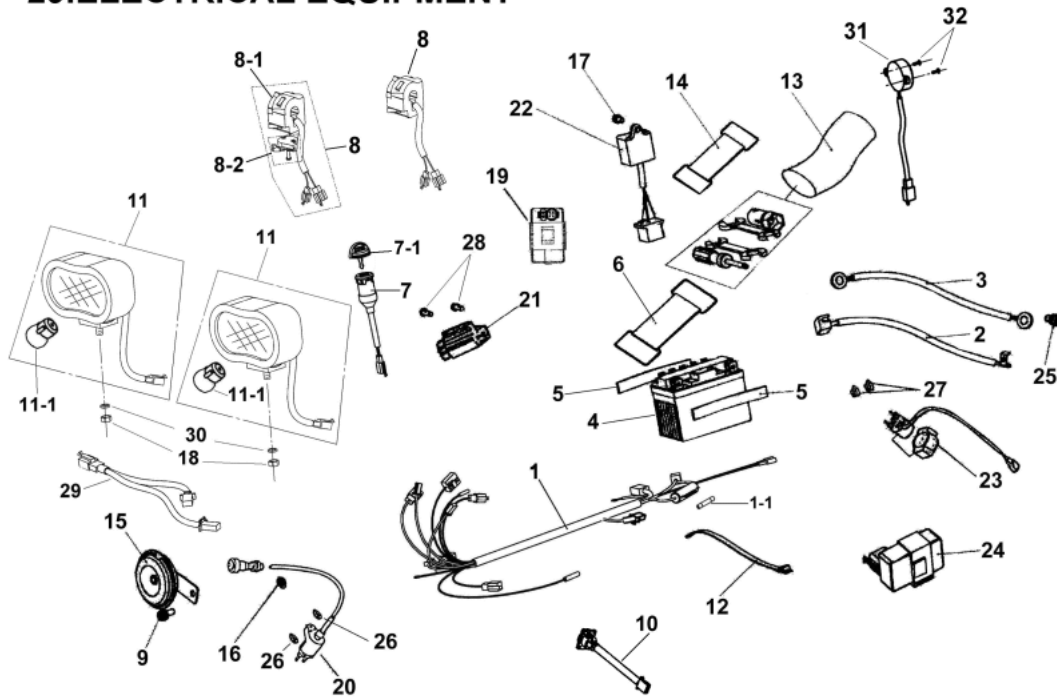

ITEM	AVAIL	PART NO.	NAME	QTY
29			ELECTRICAL EQUIPMENT	
29-1		C2100-FIA0-0000	MAIN WIRE ASSY.	1
29-1-1		C2010-FIA0-0000	FUSE (10A)	1
29-2		C2101-FIA0-0000	POSITIVE HIGHT PRESSURE CABLE	1
29-3		C2102-FIA0-1000	NEGATIVE LOW PRESSURE CABLE	1
29-4		C1500-FIA0-0000	BATTERY	1
29-5		C1501-9FA0-0000	FOAM STICK, BATTERY	2
29-6		C1502-9FA0-0000	RUBBER CLAMP, BATTERY(89L)	1
29-7		C5010-9FA0-0001	MAIN SWITCH COMP	1
29-7-1		C5013-9FA0-0000	MATERIAL KEY (RIGHT CUT)	1
29-7-2		C5018-9FA0-0000	MATERIAL KEY (LEFT CUT)	1
29-8		C5200-FIA0-0000	LEVER HOLDER ASSY., LEFT	1
29-9		I8556-06016	SCREW WASHER	1
29-11		C5030-FIB0-0001	HAED LIGHT	2
29-11-1		C5003-FIB0-0000	BULB,HEADLIGHT(12v 20w)	2
29-12		H3936-5AA0-0000	WIRE CLAMP	1
29-13		H9020-FIA0-0000	TOOL PACK	1
29-14		H9021-9FA0-0000	WIRE CLAMP	1
29-15		C8110-5BA0-E000	HORN	1
29-16		I0020-05024	BOLT HEX.	1
29-17		I8556-06012	SCREW PAN	1
29-18		I5800-08300	NUT, HEX.	2
29-19		C0410-V30-9001	UNIT COMP C.D.I (SPEED LIMIT)	1
29-20		C051A-FIA0-0010	IGNITION COIL ASSY.	1
29-21		C1600-B00-9000	RECTIFIER & REGULATOR	1
29-22		C1850-V30-0000	PTC CONTROLLER	1
29-23		C5850-A04-0000	STARA RELAY	1
29-24		C576A-V30-0000	COUPLER LIGHT UNIT	1
29-25		I8557-06012	SCREW WASHER	1
29-26		I2140-60001	WASHER	2
29-27		I2020-60000	NUT, HEX.	2
29-28		I0153-06839	SCREW	2
29-29		C5033-FIB0-0000	HEAD CAMP MAIN WIRE	1
29-30		I9901-08100	WASHER, SPRING	2
29-31		C8400-EMA0-0000	BUZZER	1
29-32		I2600-03008	SCREW, PAN	2

### 30.PACKING CASE,EXTERNAL

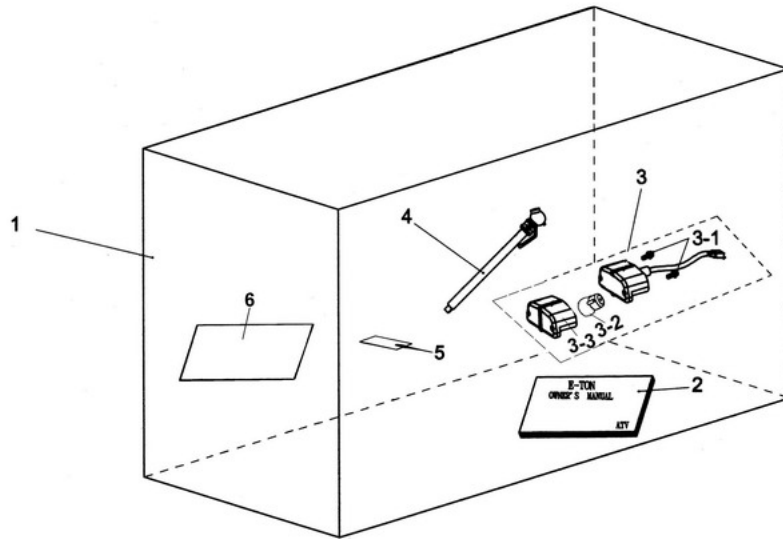

ITEM	AVAIL	PART NO.	NAME	QTY
30			PACKING CASE,EXTERNAL(DRUM BRAKE)	
30-1		H9500-FIB0-0000	PACKING CASE,EXTERNAL	1
30-2		H990A-FIB9-0000	OWNER'S MANUAL	1
30-2-1	N	H9900-FIB9-0000	OWNER'S MANUAL	1
30-3		C5031-FIA0-1000	TAIL LIGHT	1
30-3-1		I8501-06010	SCREW, PAN	2
30-3-2		C5004-FIA0-0000	BULB,TAILLIGJT(21w/5w)	1
30-3-3		C5005-FIA0-0000	LAMP SCALE	1
30-4		H9022-5EA0-0000	PRESSURE METER	1
30-6	N	H9905-FIE0-9000	EC CERTIFICATE OF CONFORMITY	1

## 31.ACCESSORIES

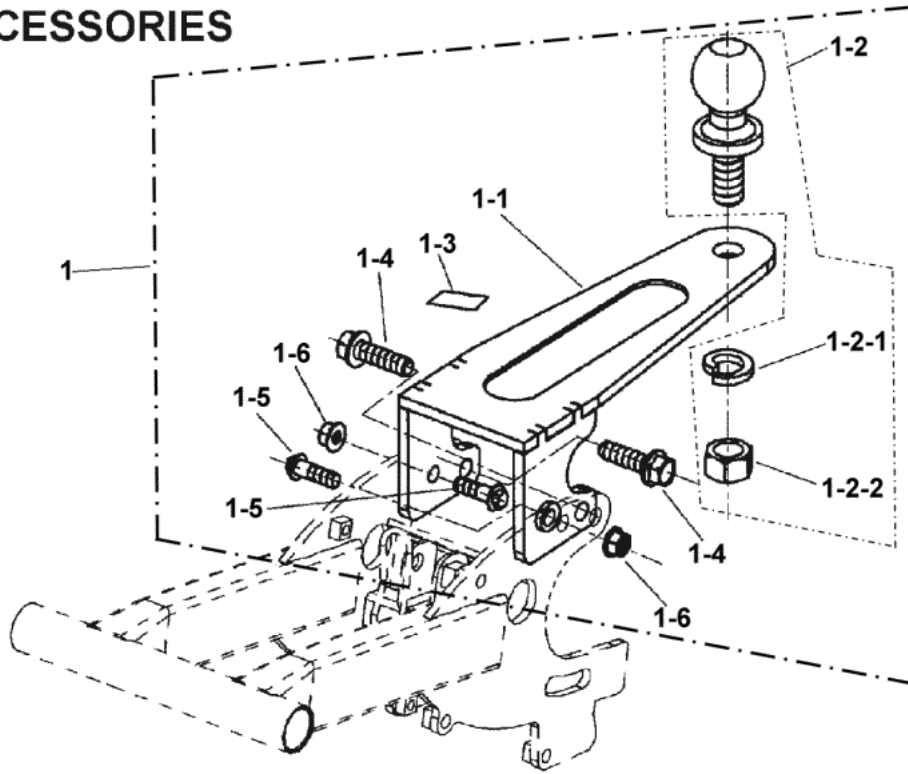

ITEM	AVAIL	PART NO.	NAME	QTY
31			ACCESSORIES	
31-1		E041C-FIB0-8000	VEHICLE A HOOK ASSY.BALL (2 inch)	1
31-1-1		E0418-FIB0-0000	VEHICLE A HOOK	1
31-1-2		MG1520-LRA0-0000	VEHICLE A HOOK BALL (2 inch)	1
31-1-2-1		I3300-20000-0B	SPRING WASHER	1
31-1-2-2		I4100-19016	NUT	1
31-1-3		H7118-FIB0-0000	STICKER,WARNING	1
31-1-4		I0141-12040-01	FLANGE BOLT, HEX.	2
31-1-5		I0149-10030	BOLT,FLANGE	2
31-1-6		I5611-10200	HEX. FLANGE NUT, SAFETY	2
31-2		MH8402-100-0800	LUGGAGE BAGS	1

No picture.

ITEM	AVAIL	PART NO.	NAME	QTY
32			KIT DESCRIPTION	
32-1		A2251-A08-0000	GASKET CYLINDER HEAD	1
32-2		A2100-A08-0000	CYLINDER COMP	1
32-3		A2191-A08-0000	GASKET CYLINDER	1
32-4		A3011-A08-0000	RING SET,PISTON	1
32-5		A3111-A08-0000	PIN,PISTON	1
32-6		A3101-A08-0000	PISTON	1
32-7		I4601-15000	CLIP,PISTON PIN 15mm	2

No picture.

ITEM	AVAIL	PART NO.	NAME	QTY
33			BUMPER ASSY	
33-1		E040A-FIB0-0000	BUMPER ASSY	1
33-1-1		E0400-FIB0-0000	BUMPER	1
33-1-2		E0413-FIB0-0000	FRONT PACK	1
33-1-3		F4001-FIC0-0000	CARRIER COVER REAR	1
33-1-3-1		C1501-FIB0-0000	FOAM-RUBBER STICK	7
33-1-3-1		C1501-FIB0-0000	FOAM-RUBBER STICK	5
33-1-3-2		H7113-9FB0-0000	CARRIER COVER,STICKER	1
33-1-3-2		H7113-9FB0-0000	CARRIER COVER,STICKER	1
33-1-4		E0117-9EA0-0000	SCREW, TRUSS	12
33-1-5		I0149-08016	FLANGE BOLT, HEX.	14
33-1-6		I5616-08200	NUTFLANGE CHECK	4
33-1-7		H9510-FIB0-0000	BOX COVER FRONT	1

No picture.

ITEM	AVAIL	PART NO.	NAME	QTY
34			TOOL	
34-1		C1110-B00-FT1	TACKING ACG FLY WHEEL TOOL	1

No picture.

ITEM	AVAIL	PART NO.	NAME	QTY
35			SERVICE KITS, BRAKE CALLIPER	
35-1		G7137-BCA0-0000	BRAKE KITS,BRAKE CALL IPER	1
35-1-1		G7134-BCA0-0000	RING, SEAL	2
35-1-2		G7135-BCA0-0000	RING, DUST RESISTANT	2
35-1-3		G7136-BCA0-0000	PISTON, BRAKE CALLIPER	2